

**WJEC**  

---

**CBAC**

**AS/A LEVEL**  
**GCE in Chemistry**

**REVISION AID**

**UNIT 1**

# AS

## **UNIT CH1 – *Controlling and Using Chemical Changes (in order to make things, produce energy and solve environmental problems)***

### **Preamble**

This unit begins with some important fundamental ideas about atoms and the use of the mole concept in calculations.

Three key principles governing chemical change are then studied, viz. the position of equilibrium between reactants and products, the energy changes associated with a chemical reaction and the rate at which reactions take place.

These principles are then applied to some important problems in the fields of chemical synthesis, obtaining energy and the maintenance of the environment.

**UNIT CH1** Controlling and Using Chemical Changes (in order to make things, produce energy and solve environmental problems)

**TOPIC 1**

**1.1 Basic ideas about atoms**

**1.2 Chemical calculations**

**TOPIC 2**

**2.1 Chemical equilibria and acid-base reactions**

**2.2 Energetics**

**2.3 Kinetics**

**TOPIC 3**



## Topic 1.1 (b)

**Learning Outcome:** *understand the terms **atomic number**, **mass number** and **isotope**, and the connection between atomic numbers and mass numbers.*

The number of protons in the nucleus of an atom is called the **atomic number (Z)**.

Each element has its own atomic number.

For example hydrogen has atomic number 1.

Lithium has atomic number 3.

Chlorine has atomic number 17.

The **number of protons plus the number of neutrons** is called the **mass number (A)**.

An atom is electrically **neutral** because the number of negative electrons surrounding the nucleus equals the number of positive protons in the nucleus.

A particle where the number of electrons does not equal the number of protons is no longer an atom but is called **an ion** and has an electrical charge.

We can define an atom in terms of the symbol for the element, the atomic number of

the atom ( $Z$ ) and the mass number ( $A$ ).  ${}^A_Z E$

For example, an atom of sodium may be represented as  ${}^{23}_{11}Na$

11 is the atomic number and 23 is the mass number.

Some elements exist as a mixture of atoms which are only different in their mass numbers. These atoms are called **isotopes**. Chlorine gas exists as a mixture of two isotopes, one having a mass number of 35 and one having a mass number of 37.

These are represented as  ${}^{35}_{17}Cl$  and  ${}^{37}_{17}Cl$

### Topic 1.1 (c)

**Learning Outcome:** deduce, given atomic and mass numbers, the numbers of protons, neutrons and electrons in specified isotopes;

Taking the isotopes above,  ${}^{35}_{17}\text{Cl}$  and  ${}^{37}_{17}\text{Cl}$ , we can deduce the numbers of electrons, protons and neutrons in each neutral atom.

isotope	atomic number(Z) = number of protons	mass number(A) = number of protons plus neutrons	number of neutrons	number of electrons
${}^{35}_{17}\text{Cl}$	17	35	18	17
${}^{37}_{17}\text{Cl}$	17	37	20	17

### Topic 1.1 (d)

**Learning Outcome:** explain the formation of ions from atoms by the loss or gain of electrons.

If a neutral atom loses one or more electrons, the atom is no longer neutral but has a positive charge. The number of protons, which are positive, is bigger than the number of negative electrons.

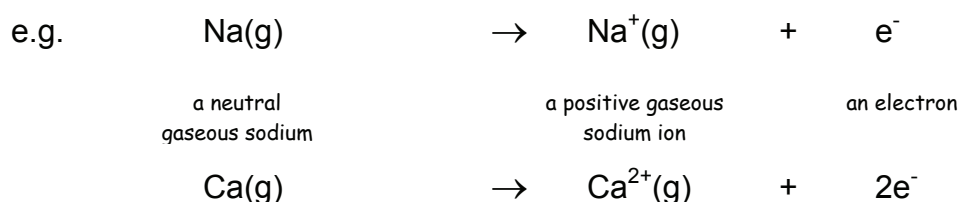

Positive ions are called **cations**.

If a neutral atom gains one or more electrons, the atom is no longer neutral but has a negative charge. The number of negative electrons is bigger than the number of protons which are positive.

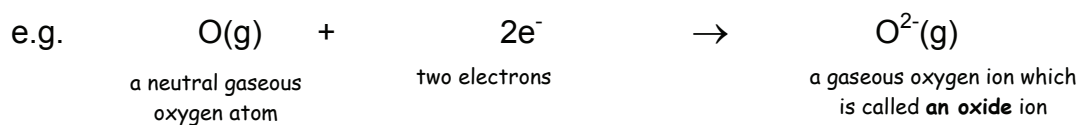

Negative ions are called **anions**.

## Topic 1.1 (e)

**Learning Outcome:** describe the nature of alpha ( $\alpha$ ) and beta ( $\beta$ ) particles and of gamma ( $\gamma$ ) radiation and recall their behaviour in electrical fields and their relative penetrative powers.

### Radioactive isotopes

Some isotopes are unstable; these are usually, but not always, heavy nuclei like those of uranium and plutonium.

The nuclei of radioactive isotopes spontaneously disintegrate and emit *either* alpha ( $\alpha$ ) particles (which are helium nuclei) *or* beta ( $\beta$ ) particles (which are electrons).

Gamma ( $\gamma$ ) rays which are very high energy radiation may also be given off.

The half-life of a radioisotope (**Topic 1.1(h)**) is the time taken for its radioactivity to fall to half of its initial value and is independent of the mass of the radioisotope.

The half-life is characteristic of each radioisotope and unaffected by catalysts or changes in temperature.

### Types of radioactive emissions.

Radiation	nature	mass	penetrating power
$\alpha$ - particle	${}^4_2\text{He}^{2+}$	4 units	the least penetrating radiation stopped by a piece of paper
$\beta$ - particle	an electron	negligible	stopped by a thin sheet of metal ( 0.5 cm of aluminium)
$\gamma$ - rays	high energy electro-magnetic radiation	negligible	may take more than 2 cm of lead to stop $\gamma$ - radiation

### Behaviour of radioactive radiation in an electric field

**$\alpha$ - particles** are positive, heavy and slow moving and are attracted slightly to the negative plate of an electric field

**$\beta$ - particles** are light and fast moving and show considerable deviation towards the positive plate of the electric field

**$\gamma$  radiation** is electromagnetic radiation of short wavelength and is unaffected by an electric field.

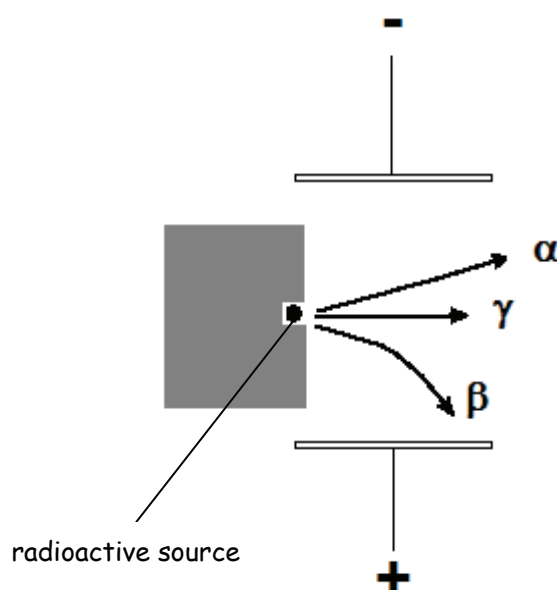

## Topic 1.1 (f)

**Learning Outcome:** describe and explain the changes in mass number and atomic number resulting from alpha ( $\alpha$ ) and beta ( $\beta$ ) emission

It is important to note that these radiations come from **the nucleus of the atom**.

This means that *alpha* ( $\alpha$ ) and *beta* ( $\beta$ ) radioactive emissions result in the formation of a new nucleus with a new atomic number and the product is a different element.  $\gamma$  radiation reduces the energy of the nucleus.

Examples

### alpha emission ( $\alpha$ )

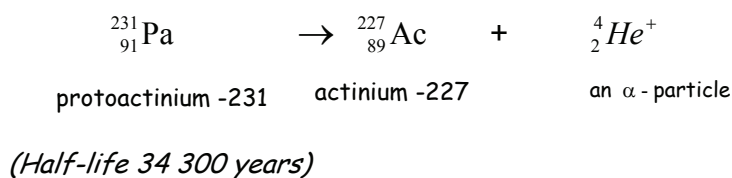

**The product (the daughter isotope) is two places to the left in the Periodic Table and has a mass number smaller by four.**

### beta emission ( $\beta$ )

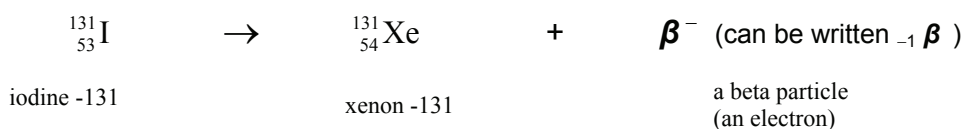

*half-life 8.06 days*

**The product is an element one place to the right in the Periodic Table with the same mass number.**

This may be summarised by saying that a neutron in the nucleus has changed to a proton and an electron.

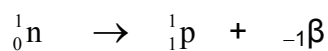

This is a simplification because another particle called a neutrino is formed at the same time but knowledge of the neutrino is not required at this level. (A neutrino has no charge and a rest mass of zero.)

## Topic 1.1 (g)

**Learning Outcome:** describe the adverse consequences for living cells of exposure to  $\gamma$ -radiation and to  $\alpha$ - and  $\beta$ -emitters;

We all receive radiation which is called background radiation, arising from naturally occurring radioactive sources, man-made radiation and radiation reaching the Earth from space.

### APPROXIMATE TOTAL YEARLY RADIATION EXPOSURE IN THE UK

**NATURAL 84%**

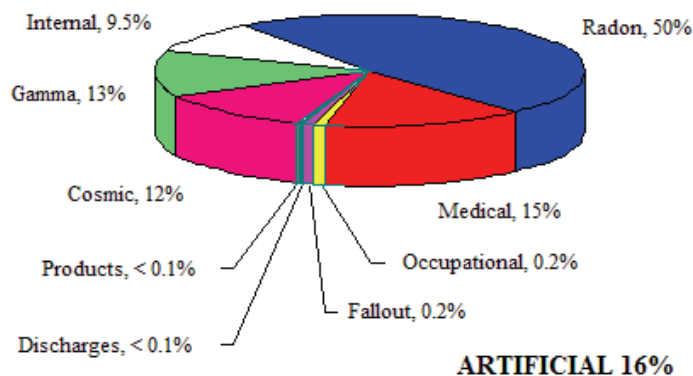

Source  
Health Protection Agency  
Press Release May 2005

Average annual dose to the UK population from all sources, 2.7mSv

The sievert is the unit of radiation dose being that delivered in one hour at a distance of 1 cm from a point source of 1mg of radium element enclosed in platinum of thickness 0.5 mm

### The effects of radioactive radiation on living

All radioactive radiation is potentially harmful. High energy alpha and beta particles can damage cells and DNA, as can the highly penetrating gamma rays. Changes in DNA can cause mutations of genes with unfortunate genetic effects and the production of cancer causing cells.

Leukaemia is a common illness produced by radiation. Although alpha particles are usually unable to penetrate the skin, when ingested they are extremely toxic. The murder of the Russian, Alexander Litvinenko, in 2006, was brought about by the alpha emitter polonium-210. Exposure to all three radiations can cause irreversible organ damage.

It is known that exposure to radiation can cause cell mutation leading to carcinomas and to forms of leukaemia. Even small increases in the background level of radiation may have significant effects on the population as a whole. This is because the probability for cell mutation is higher when applied to a large population sample.

Clusters of childhood leukaemia have been associated with the children of fathers working at nuclear plants but numerous enquiries have not found any firmly established link between the radiation received by the fathers and the development of the disease in the children. There appears to be some evidence that the incidence of childhood leukaemia near nuclear installations may be related to the influx of a large number of workers into a previously isolated society. This results in the development of viral and bacterial cross-infections that in turn may cause leukaemia.

The beta-emitter iodine-131 has been shown to cause thyroid cancer.

Some detailed information may be obtained from Practical Radiation Technical Manual published by The International Atomic Energy Agency in Vienna. This may be downloaded from

[http://www-pub.iaea.org/MTCD/publications/PDF/PRTM-3r1\\_web.pdf](http://www-pub.iaea.org/MTCD/publications/PDF/PRTM-3r1_web.pdf)



The effects of high levels of radiations have been studied following the atomic bombs at Hiroshima and Nagasaki and more recently after the nuclear accident at Chernobyl.

There is much information on the Internet; the following sites may be of interest.

<http://www.atomicinsights.com/apr96/effects.html>



[http://library.thinkquest.org/3471/radiation\\_effects\\_body.html](http://library.thinkquest.org/3471/radiation_effects_body.html)



### Topic 1.1(h)

**Learning Outcome:** *explain what is meant by the half-life of a radioactive isotope; perform simple calculations involving integral numbers of half-lives;*

#### Example using half-life.

The isotope iodine -131 occurs in the spent fuel rods from nuclear reactors. Before processing, the fuel rods are stored under water for 56 days.

*If the half-life of iodine-131 is eight days,  
what fraction of the original iodine-131  
activity remains after the storage period?*

## Topic 1.1(i)

**Learning Outcome:** *apply their knowledge of radioactive decay and half-life to contexts in health, medicine, radio-dating and analysis;*

### Radiocarbon dating.

The naturally occurring element carbon has the following composition: - .

C12 - 98.89%,      C13 - 1.11%      and      C14 - 0.00000000010%.

Carbon -12 and carbon-13 are stable but carbon-14 is a beta emitter with a half-life of  $5568 \pm 30$  years.

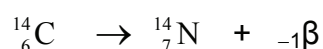

The  ${}^{14}\text{C}$  is formed in the upper atmosphere by cosmic radiation where neutrons bombard nitrogen atoms to produce  ${}^{14}\text{C}$  which then enters the carbon cycle. All living organisms absorb  ${}^{14}\text{C}$  and the amount of carbon-14 per gram of carbon in living organisms is constant at about  $15.3 \text{ counts min}^{-1} (\text{g of carbon})^{-1}$ . When an organism dies there is no more absorption of  ${}^{14}\text{C}$  and the radioactivity due to the isotope decays.

Measurement of the carbon-14 radioactivity per gram of carbon in an archaeological artefact of animal or vegetable origin gives an estimate of the time that has elapsed since the organism died. This is known as **carbon dating**.



Visit

[http://archserve.id.ucsb.edu/Anth3/Courseware/Chronology/08\\_Radiocarbon\\_Dating.html](http://archserve.id.ucsb.edu/Anth3/Courseware/Chronology/08_Radiocarbon_Dating.html)

(\*you may need Macromedia Shockwave.)

Attempts at geological dating of rocks have been made by using the fact that an atom of potassium-40 can capture an inner electron to become an atom of argon-40, the process has a half-life of  $1.3 \times 10^9$  years. Knowledge of this process called "K-capture" is not needed for this specification.

### Analysis

Radioactive isotopes have been used in several analytical methods. One method is known as **dilution analysis**.

### As tracers

Radioactive phosphorus has been used to follow what happens to the element phosphorus in the biochemistry of green plants.

Visit [http://www.chem.duke.edu/~jds/cruise\\_chem/nuclear/uses.html](http://www.chem.duke.edu/~jds/cruise_chem/nuclear/uses.html)



## Topic 1.1(j)

**Learning Outcome:** *understand and explain the significance of standard molar ionisation energies of gaseous atoms and their variation from one element to another;*

### Ionization energies

If we supply enough energy (electrical or heat) to any gaseous atoms they can lose electrons and become ionized.

The **molar\* first ionization** of an element is the energy required to remove one mole\* of electrons from one mole of its gaseous atoms:

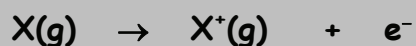

If this energy is referred to standard thermodynamic conditions 298K and atmospheric pressure it is *the **standard molar first ionization of an element.***

The **molar second ionization** of an element is the energy required to remove one mole of electrons from one mole of its gaseous unipositive ions:

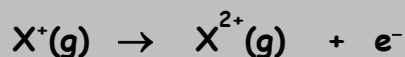

(\* see later for definition of the mole, **Topic 1.2(a).**)

If standard molar first ionisation energy is plotted against the atomic number of the element, for the first twenty elements, the graph below is obtained.

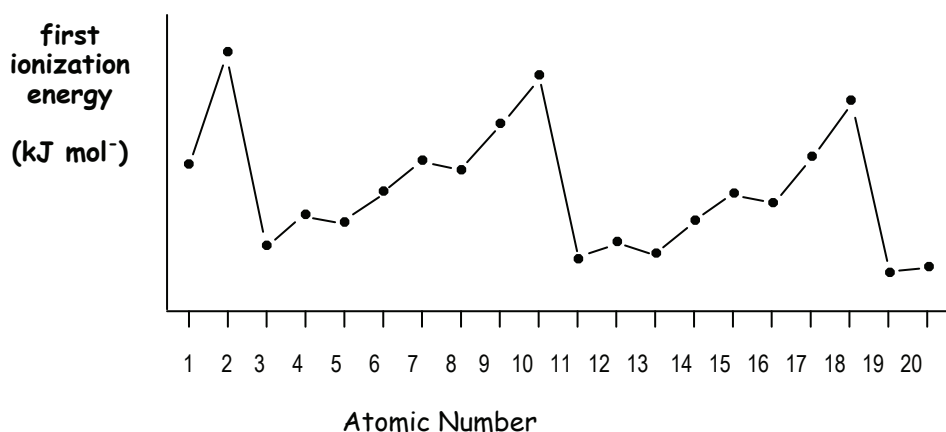

If we look at the successive ionisation energies for the electrons in an atom of sodium, the following plot can be obtained.

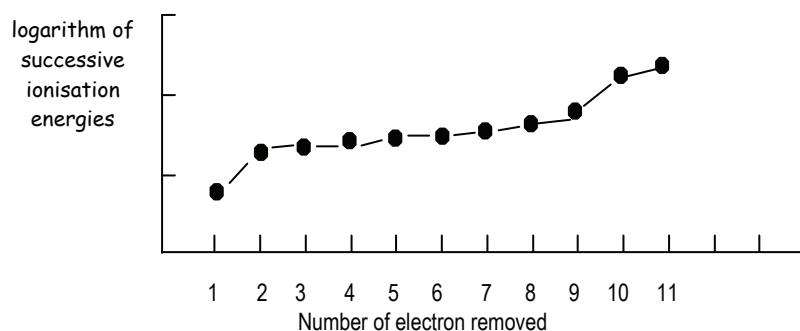

The first graph shows that as the nuclear charge increases, the molar first ionisation energy does not increase uniformly. The second graph seems to indicate that the electrons in an atom exist in distinct energy levels. For sodium, shown above, there is one electron on its own which is the easiest to remove. Then there are eight electrons which become successively more difficult to remove. Finally there are two electrons which are the most difficult to remove.

You will already know that the electrons in an atom have a definite arrangement called the electronic structure or *electronic configuration*.

## Topic 1.1 (l)

**Learning Outcome:** *describe the shapes of s and p orbitals;*

We should now know that there is a volume of space in which there is a high probability of finding an electron. Such a volume is known as a **subshell** or **orbital**.

Subshells are described by a letter, s, p, d or f.

Any one orbital can hold a maximum of two electrons. An orbital is described by one other number called the **principal quantum number**, which can be thought of as an energy level, and has the integral values 1,2,3,4 etc.

The principal quantum number describes the energy level or shell. The letters s, p, d, f describe the sub-shell.

The specification requires that you can recall the shapes of s and p orbitals.

An s orbital has spherical symmetry

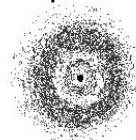

A p orbital is made up of three dumbbell shaped lobes mutually at right angles.

They are shown separated below

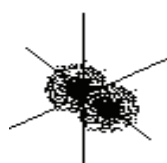

$p_x$  orbital



$p_y$  orbital

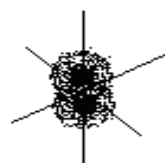

$p_z$  orbital

An s orbital can contain two electrons, the  $p_x$ ,  $p_y$  and  $p_z$  orbitals can each hold two electrons making six electrons in all.

## Topic 1.1(m)

**Learning Outcome:** *recall the appropriate s, p and d orbital occupations for elements 1 - 36 (using 'arrows in boxes' or otherwise) and relate these to position in the Periodic Table.*

The two electrons in an orbital differ only in terms of spin.

This can be shown by denoting the orbital by boxes containing electrons represented by arrows.

The arrows are up and down representing opposite spin.

You may need to be able to draw arrow in boxes arrangements in the examination.



## Notes.

The 4s orbitals are filled before the 3d orbitals, see K and Ca

Electrons fill orbitals of the same energy singly before pairing. Note especially Cr and Cu.

When an atom receives energy, electrons may be promoted to higher energy orbitals. The above electronic configurations are therefore called **ground state** configurations.

Often we write the ground state electronic configurations more simply as

H	1	1s
He	2	1s <sup>2</sup>
Li	3	1s <sup>2</sup> 2s
Be	4	1s <sup>2</sup> 2s <sup>2</sup>
B	5	1s <sup>2</sup> 2s <sup>2</sup> 2p <sup>1</sup>
C	6	1s <sup>2</sup> 2s <sup>2</sup> 2p <sup>2</sup>
N	7	1s <sup>2</sup> 2s <sup>2</sup> 2p <sup>3</sup>
O	8	1s <sup>2</sup> 2s <sup>2</sup> 2p <sup>4</sup>
F	9	1s <sup>2</sup> 2s <sup>2</sup> 2p <sup>5</sup>
Ne	10	1s <sup>2</sup> 2s <sup>2</sup> 2p <sup>6</sup>
Na	11	1s <sup>2</sup> 2s <sup>2</sup> 2p <sup>6</sup> 3s <sup>1</sup>
Mg	12	1s <sup>2</sup> 2s <sup>2</sup> 2p <sup>6</sup> 3s <sup>2</sup>
Al	13	1s <sup>2</sup> 2s <sup>2</sup> 2p <sup>6</sup> 3s <sup>2</sup> 2p <sup>1</sup>
Si	14	1s <sup>2</sup> 2s <sup>2</sup> 2p <sup>6</sup> 3s <sup>2</sup> 2p <sup>2</sup>
P	15	1s <sup>2</sup> 2s <sup>2</sup> 2p <sup>6</sup> 3s <sup>2</sup> 2p <sup>3</sup>
S	16	1s <sup>2</sup> 2s <sup>2</sup> 2p <sup>6</sup> 3s <sup>2</sup> 2p <sup>4</sup>
Cl	17	1s <sup>2</sup> 2s <sup>2</sup> 2p <sup>6</sup> 3s <sup>2</sup> 2p <sup>5</sup>
Ar	18	1s <sup>2</sup> 2s <sup>2</sup> 2p <sup>6</sup> 3s <sup>2</sup> 2p <sup>6</sup>
K	19	1s <sup>2</sup> 2s <sup>2</sup> 2p <sup>6</sup> 3s <sup>2</sup> 2p <sup>6</sup> 4s <sup>1</sup>
Ca	20	1s <sup>2</sup> 2s <sup>2</sup> 2p <sup>6</sup> 3s <sup>2</sup> 2p <sup>6</sup> 4s <sup>2</sup>
Sc	21	1s <sup>2</sup> 2s <sup>2</sup> 2p <sup>6</sup> 3s <sup>2</sup> 2p <sup>6</sup> 3d <sup>1</sup> 4s <sup>2</sup>
Ti	22	1s <sup>2</sup> 2s <sup>2</sup> 2p <sup>6</sup> 3s <sup>2</sup> 2p <sup>6</sup> 3d <sup>2</sup> 4s <sup>2</sup>
V	23	1s <sup>2</sup> 2s <sup>2</sup> 2p <sup>6</sup> 3s <sup>2</sup> 2p <sup>6</sup> 3d <sup>3</sup> 4s <sup>2</sup>
Cr	24	1s <sup>2</sup> 2s <sup>2</sup> 2p <sup>6</sup> 3s <sup>2</sup> 2p <sup>6</sup> 3d <sup>5</sup> 4s <sup>1</sup>
Mn	25	1s <sup>2</sup> 2s <sup>2</sup> 2p <sup>6</sup> 3s <sup>2</sup> 2p <sup>6</sup> 3d <sup>5</sup> 4s <sup>2</sup>
Fe	26	1s <sup>2</sup> 2s <sup>2</sup> 2p <sup>6</sup> 3s <sup>2</sup> 2p <sup>6</sup> 3d <sup>6</sup> 4s <sup>2</sup>
Co	27	1s <sup>2</sup> 2s <sup>2</sup> 2p <sup>6</sup> 3s <sup>2</sup> 2p <sup>6</sup> 3d <sup>7</sup> 4s <sup>2</sup>
Ni	28	1s <sup>2</sup> 2s <sup>2</sup> 2p <sup>6</sup> 3s <sup>2</sup> 2p <sup>6</sup> 3d <sup>8</sup> 4s <sup>2</sup>
Cu	29	1s <sup>2</sup> 2s <sup>2</sup> 2p <sup>6</sup> 3s <sup>2</sup> 2p <sup>6</sup> 3d <sup>10</sup> 4s <sup>1</sup>
Zn	30	1s <sup>2</sup> 2s <sup>2</sup> 2p <sup>6</sup> 3s <sup>2</sup> 2p <sup>6</sup> 3d <sup>10</sup> 4s <sup>2</sup>
Ga	31	1s <sup>2</sup> 2s <sup>2</sup> 2p <sup>6</sup> 3s <sup>2</sup> 2p <sup>6</sup> 3d <sup>10</sup> 4s <sup>2</sup> 4p <sup>1</sup>
Ge	32	1s <sup>2</sup> 2s <sup>2</sup> 2p <sup>6</sup> 3s <sup>2</sup> 2p <sup>6</sup> 3d <sup>10</sup> 4s <sup>2</sup> 4p <sup>2</sup>
As	33	1s <sup>2</sup> 2s <sup>2</sup> 2p <sup>6</sup> 3s <sup>2</sup> 2p <sup>6</sup> 3d <sup>10</sup> 4s <sup>2</sup> 4p <sup>3</sup>
Se	34	1s <sup>2</sup> 2s <sup>2</sup> 2p <sup>6</sup> 3s <sup>2</sup> 2p <sup>6</sup> 3d <sup>10</sup> 4s <sup>2</sup> 4p <sup>4</sup>
Br	35	1s <sup>2</sup> 2s <sup>2</sup> 2p <sup>6</sup> 3s <sup>2</sup> 2p <sup>6</sup> 3d <sup>10</sup> 4s <sup>2</sup> 4p <sup>5</sup>
Kr	36	1s <sup>2</sup> 2s <sup>2</sup> 2p <sup>6</sup> 3s <sup>2</sup> 2p <sup>6</sup> 3d <sup>10</sup> 4s <sup>2</sup> 4p <sup>6</sup>

## Topic 1.1(k)

**Learning Outcome:** describe and explain how information about the electronic structure of atoms may be deduced from values of successive ionisation energies;

We can now modify the ionisation energy plots we have come across by labelling the outer electrons and energy levels.

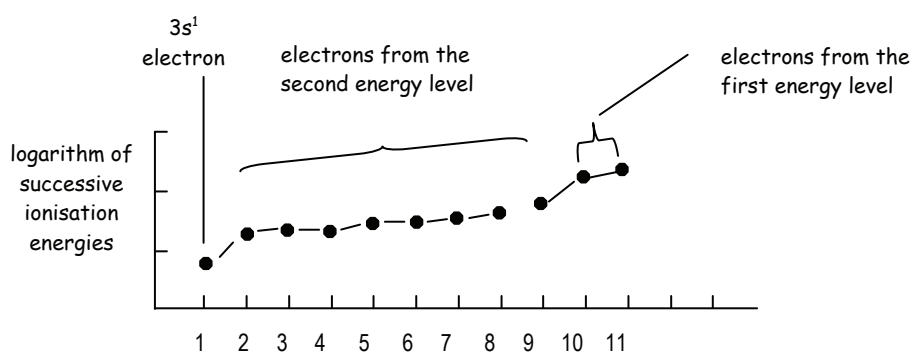
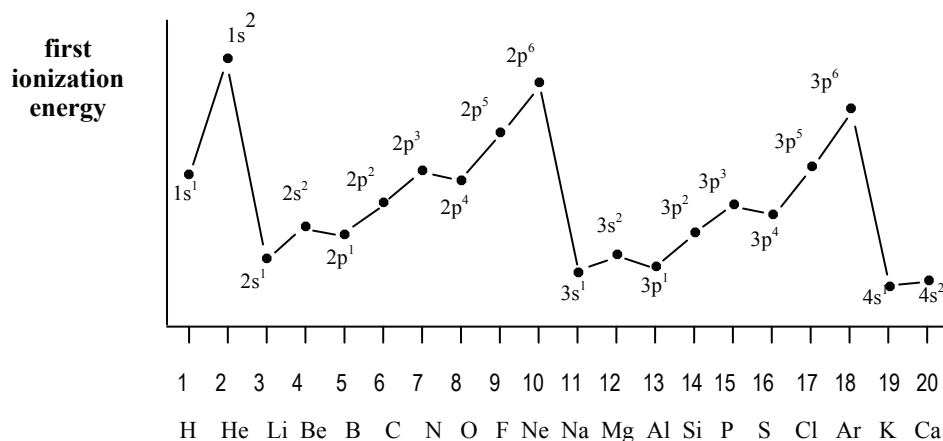

At this stage it is possible to make some generalisations about molar first ionisation energies.

- the values decrease down a group in the Periodic Table
- the values tend to increase across a period.

Two factors which affect first ionisation are the nuclear charge of the atom and the distance the electron is away from the nucleus.

The nuclear charge is measured by the atomic number of the element. The distance of the electron from the nucleus is related to the energy level - e.g. a 4s electron is further away from the nucleus than a 2s electron.

However, with increasing nuclear charge there is an increase in the total number of electrons in the atom. Due to repulsion between electrons, the inner electrons tend to reduce the effect of the nucleus on the outer electron which is removed in ionisation.

This is known as **shielding or screening**.

We can now suggest reasons for the decreases between

- beryllium and boron;
- magnesium and aluminium;
- nitrogen and oxygen;
- phosphorus and sulphur.

Look at the electronic configurations as shown by arrows in boxes.

**beryllium and boron;** the new electron goes into the 2p sub-shell and has some shielding by the 2s electrons.

**magnesium and aluminium;** the new electron goes into the 3p sub-shell and has some shielding by the 3s electrons.

**nitrogen and oxygen;** the new electron enters an orbital which is already singly occupied and the repulsion between the two electrons causes the ionisation energy to fall, i.e. the electron is easier to remove.

**phosphorus and sulphur;** ; the new electron enters an orbital which is already singly occupied and the repulsion between the two electrons causes the ionisation energy to fall, i.e. the electron is easier to remove.

See how the Periodic Table looks in terms of s, p and d electrons

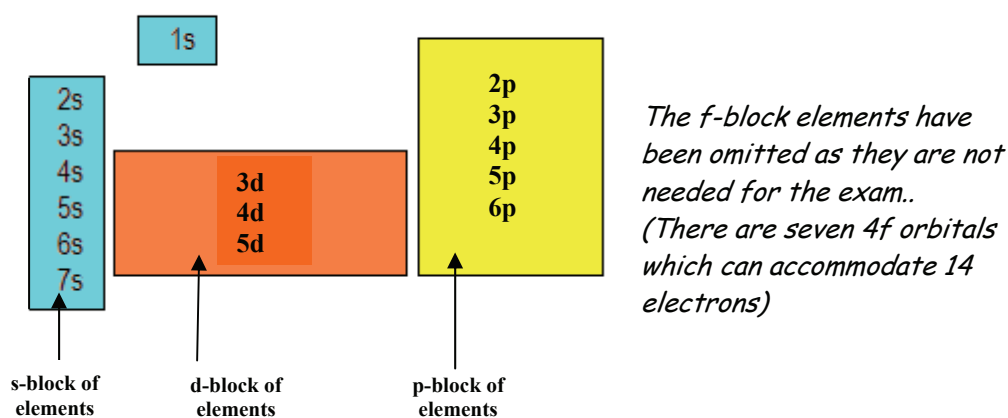

### Summary:-

- an s sub-shell can hold up to two electrons, the s-block is two elements wide.
- a p sub-shell can hold up to six electrons, the p-block is six elements wide.
- a d sub-shell can hold up to ten electrons, the d-block is ten elements wide.
- an f sub-shell can hold up to fourteen electrons

The order for putting electrons into orbitals is

1s  
 2s 2p  
 3s 3p  
 4s 3d 4p  
 5s 4d 5p  
 6s 4f 5d 6p  
 7s 5f 6d 7p

## Topic 1(n) – 1(q)

### Learning Outcome:

- (n) *explain the origin of emission and absorption spectra in terms of electron transitions between atomic energy levels;*
- (o) *describe and interpret the visible atomic spectrum of the hydrogen atom (Balmer Series);*
- (p) *recall the direct proportionality between energy and frequency, as implied by  $E = hf$ , and the inverse relationship between frequency and wavelength;  
(No calculations will be set.)*
- (q) *show understanding of the relationship between the frequency of the convergence limit of the Lyman Series and the ionisation energy of the hydrogen atom;*

### Emission and absorption spectra.

When atoms are given energy by heating or by an electrical field, electrons are pushed up from a lower energy level to a high energy level. We say the electron is promoted. When the source of energy is removed, the electrons fall from their high energy level (sometimes called an excited state) to a lower energy level and the energy lost is released as a packet of energy called **a quantum** of energy.

The frequency( $f$ ) of the electromagnetic radiation is related to the energy( $E$ ) by the equation

$$E = hf$$

Where  $E$  is the energy and  $f$  is the frequency of the radiation.

$h$  is a constant called Planck's constant and has the value  $6.63 \times 10^{-34}$  J s.

The frequency  $f$  of the radiation is related to the wavelength ( $\lambda$ ) by

$$\lambda = c/f \text{ where } c \text{ is the velocity of light.}$$

This kind of radiation is observed in a flame test. Elements such as sodium, potassium, strontium and barium emit light of a characteristic colour when heated in a Bunsen burner flame.

When white light is passed through a prism, or diffraction grating, the characteristic rainbow spectrum is formed. When light from a flame test source is examined by a prism in a spectrometer, the light does not split up into a continuous spectrum like white light but form a series of sharp distinct lines.

Visit <http://jersey.uoregon.edu/vlab/elements/Elements.html>



where you can see the spectra of the elements and the wavelengths of the lines which make up the spectra. e.g

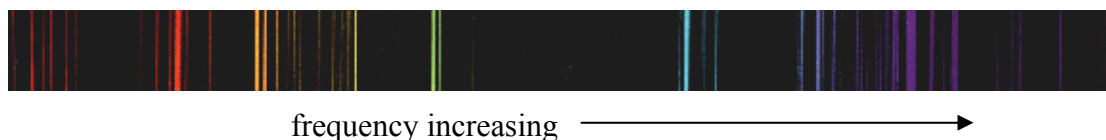

### A sketch of part of the emission spectrum of barium

The simplest emission spectrum is that of atomic hydrogen which has only one electron. An animated explanation may be found on



<http://www.mhhe.com/physsci/chemistry/essentialchemistry/flash/linesp16.swf>

The emission spectrum of atomic hydrogen contains a number of series of lines only one of which, the Balmer series, is in the visible region of the spectrum. The way these series arise may be seen from the following diagram of electronic transitions. The downward arrows show electrons falling from high energy levels to lower energy levels.

Each downward arrow will produce a line in the spectrum.

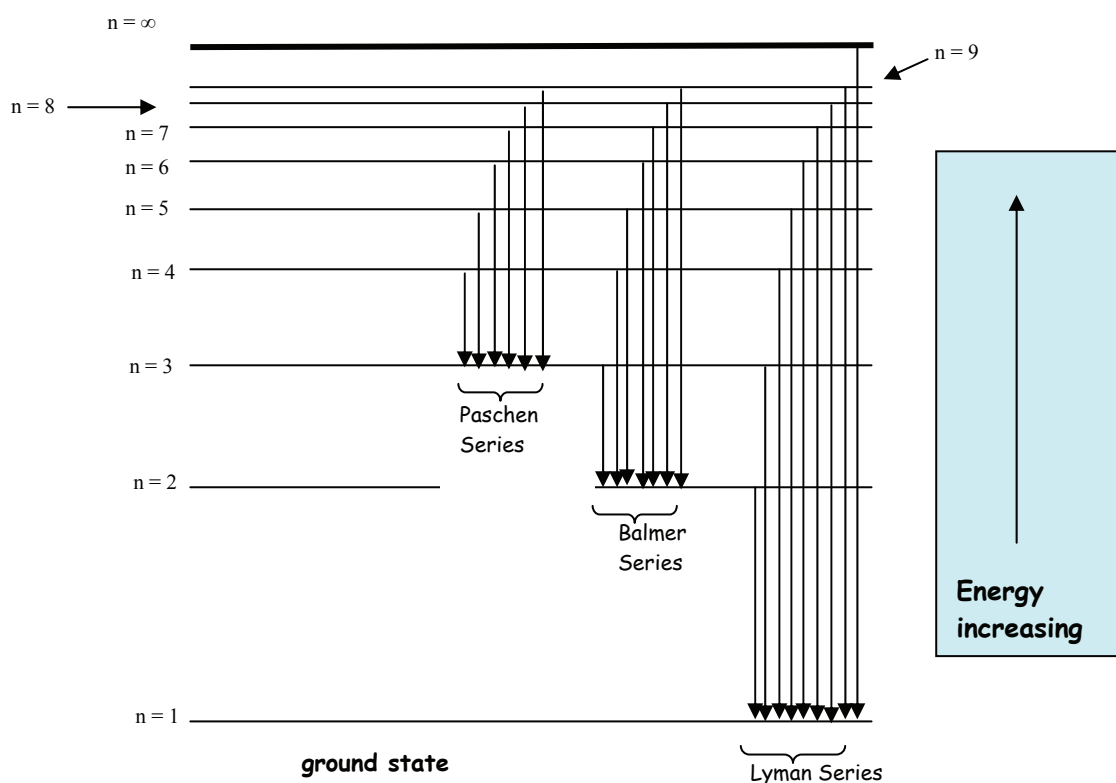

**Diagram showing how three series of lines are formed in the emission spectrum of atomic hydrogen.**

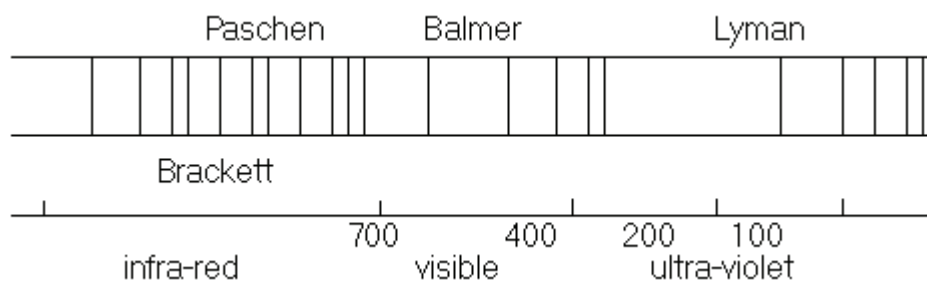

The Lyman series occurs in the ultraviolet region of the electromagnetic spectrum. The transition from  $n=1$  to  $n = \infty$  corresponds to the atom losing the electron completely. That is, the atom of hydrogen has been ionized.

In the Lyman series, the spectral lines become closer and closer together as the frequency of the radiation increases until they converge to a limit. The frequency of this convergence limit corresponds to the energy required to remove the electron .i.e. the ionization energy.

Measuring the convergent frequency allows the ionization to be calculated from  $E = hf$ .

### The Balmer Series

The four prominent lines in the Balmer series

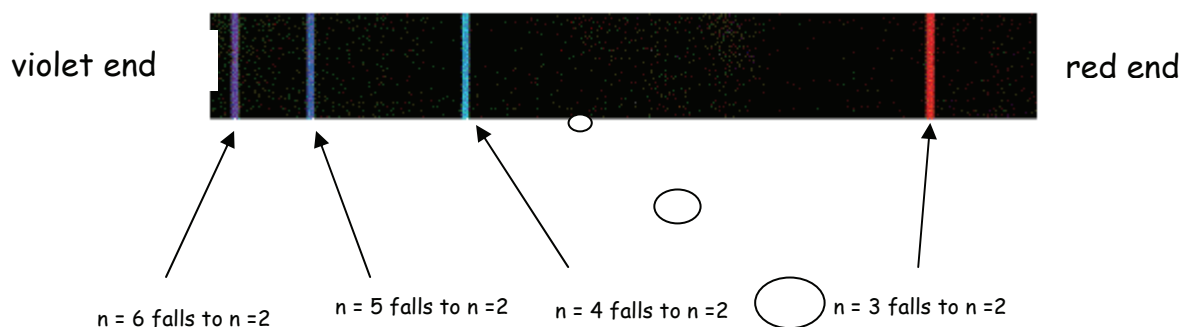

Note this diagram is in reverse to the one above - the energy increases from right to left.

## Absorption Spectra

When white light shines through gaseous atoms, photons of certain energy may be absorbed by an atom causing an electron to move from a lower energy level to a higher one. This means that light of a frequency corresponding to the energy of the photon will be removed.

Thus when the light is examined by a spectrometer, the electronic transitions will appear as dark lines against a bright background.



White light gives a continuous spectrum containing all the colours of the rainbow.

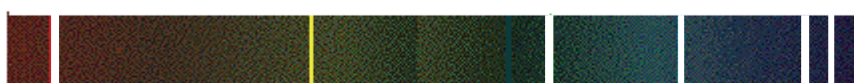

An emission spectrum consists of a series of bright lines against a dark background



An absorption spectrum consists of a series of dark lines against a bright background

Visit <http://jersey.uoregon.edu/vlab/elements/Elements.html>



to view the emission and absorption spectra of the elements.

The element helium was discovered by its absorption spectrum in solar radiation by Sir Joseph Lockyer in 1868 before being isolated on Earth by Sir William Ramsay in 1895.

**Topic 1.2(a)**

**Learning Outcome:** *Understand the term relative atomic mass, relative isotopic mass, relative molecular mass and molar mass, based on the  $^{12}\text{C}$  scale, and of the Avogadro constant, and define the mole in terms of the  $^{12}\text{C}$  isotope.*

Chemists need to know how much of a chemical they are using.

One measure of this is its mass. However, as matter is made up of atoms, molecules, ions etc. they need to know how many atoms, molecules, ions etc. and for this they use **amount of substance**.

The **amount of substance** is measured in **moles**.

*One mole is defined as the same number of particles as there are atoms of carbon in exactly twelve grams of  $^{12}_6\text{C}$ .*

This turns out to be a rather large number:

approximately 602 200 000 000 000 000 000 or  $6.022 \times 10^{23}$ . This is called the Avogadro constant,  $L$ .

When using the word **mole** to describe amount of substance it is important to state the particles to which it refers.

One mole of oxygen atoms **is not the same** as one mole of oxygen molecules.

**Relative atomic mass**

Naturally occurring elements often contain a mixture of isotopes. This means that some atoms have a different mass from other atoms. In order to overcome this, chemists use an average mass of all the atoms and this is called the relative atomic mass.

**Relative atomic mass** is defined as  
*The weighted average mass of all the atoms in a normal isotopic sample of the element, on the scale where one atom of  $^{12}_6\text{C}$  has the mass of twelve exactly.*

e.g.  $A_r(\text{Na}) = 23.0$

Note relative atomic mass has no units since it is one mass compared to another mass.

**Relative isotopic mass** is defined as :

*the mass of an atom of a particular isotope on the scale where one atom of  $^{12}_6\text{C}$  has a mass of twelve exactly.*

Many substances exist as individual molecules made up of atoms chemically combined.

Examples are water,  $\text{H}_2\text{O}$ , and carbon dioxide,  $\text{CO}_2$ .

The relative molecular mass can be found from the relative atomic masses of the elements of which it is composed and its formula. The value of the relative molecular mass is again based on the standard of  $^{12}_6\text{C}$ .

The relative molecular mass,  $M_r$ , for water ( $\text{H}_2\text{O}$ ) is  $(2 \times 1.01) + 16.0 = 18.02$

for carbon dioxide ( $\text{CO}_2$ ), it is  $12.0 + (2 \times 16.0) = 44.0$

Note that 18.02 g of water will be the mass of one mole of water molecules and contain  $6.022 \times 10^{23}$   $\text{H}_2\text{O}$  molecules.

44.0 g of carbon dioxide will be the mass of one mole of carbon dioxide molecules and

contain  $6.022 \times 10^{23}$   $\text{CO}_2$  molecules.

$18 \text{ g mol}^{-1}$  is the **molar mass** of water. Note **molar mass** has the units,  $\text{g mol}^{-1}$ , unlike **relative molecular mass** which has no units.

A compound like sodium chloride exists as a giant ionic crystal and does not contain individual molecules.

It would be wrong to speak of the relative molecular mass of sodium chloride,  $\text{NaCl}$ .

We could say that **the relative formula mass** of sodium chloride is  $(23.0 + 35.5) = 58.5$  and that the **molar mass** of sodium chloride is  $58.5 \text{ g mol}^{-1}$ .

## Topic 1.2(b)

**Learning outcome:** explain the principles of the mass spectrometer and understand its uses, including the determination of the relative abundance of isotopes, relative isotopic and relative atomic masses, and describe and explain the mass spectrum of the chlorine molecule.

### The mass spectrometer.

A simplified diagram of a mass spectrometer is shown below. It will not be necessary to reproduce this diagram in an examination but the principles involved will be required.

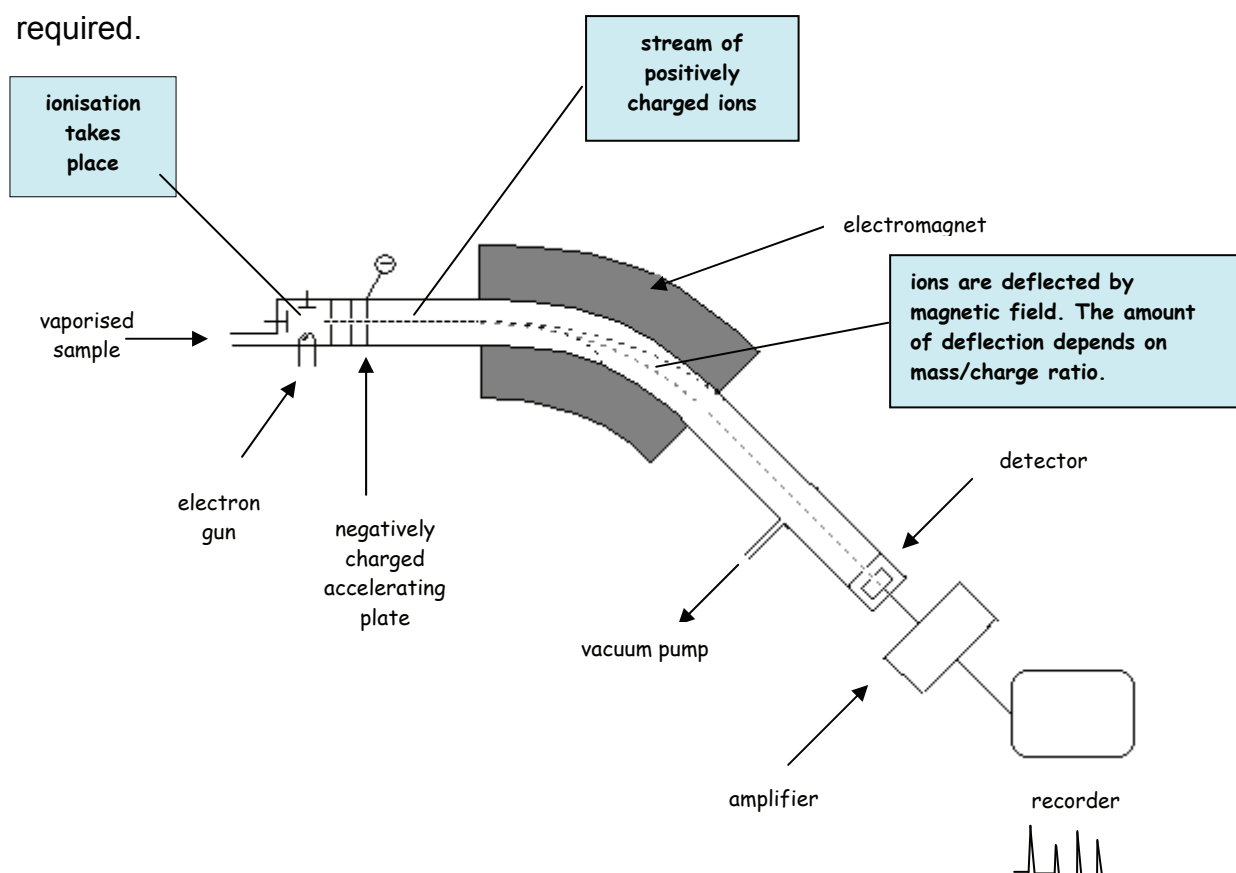

### The processes may be summarised as

Gaseous sample – ionised by high speed electrons – positive particles formed – collimated to a narrow beam – which is accelerated towards a negative plate – enters a magnetic field – particles are deflected according to their mass/ charge ratio – detected – signal amplified and recorded. By changing the strength of the magnetic field all positive ions are detected.

The result is a mass spectrum.

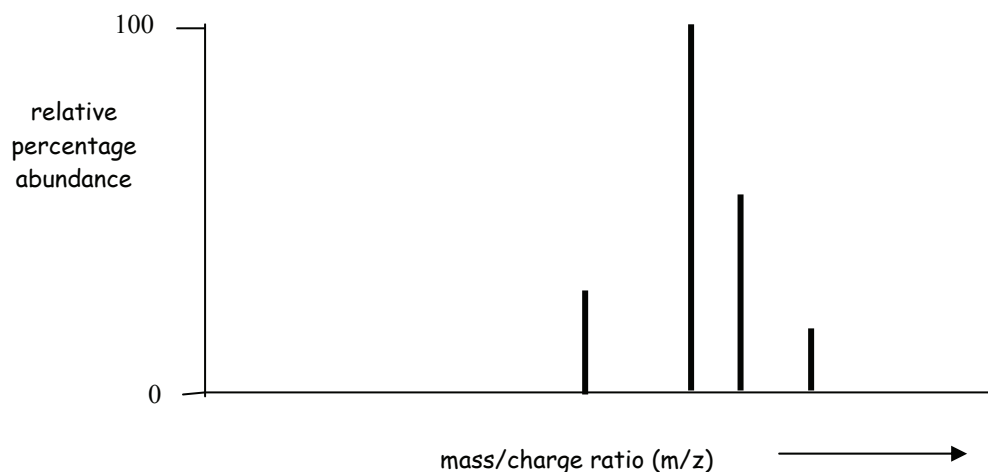

It is common practice to describe peaks in terms of the percentage abundance compared with the peak for the most abundant ion (the base peak) which is assigned the value of 100.

**To find relative atomic mass of an element.**

The element magnesium is made up of three isotopes,  $^{24}_{12}\text{Mg}$ ,  $^{25}_{12}\text{Mg}$  and  $^{26}_{12}\text{Mg}$ , the mass spectrum is shown below.

Remember that the relative atomic mass is a weighted average of the masses of all the atoms in the isotopic mixture.

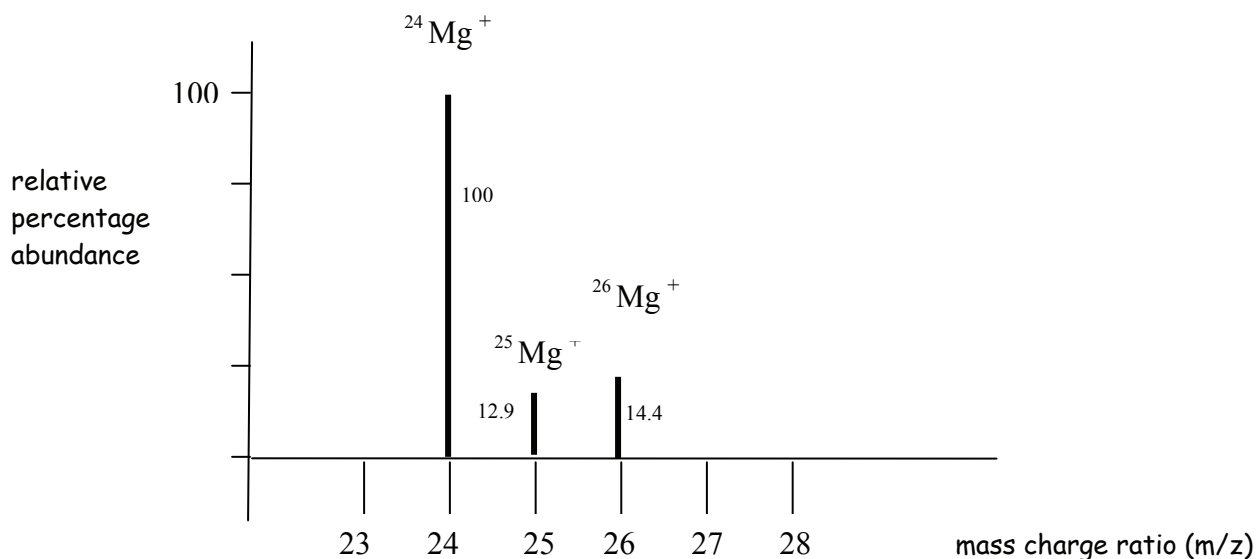

The relative atomic mass is

$$\frac{(100 \times 24) + (12.9 \times 25) + (14.4 \times 26)}{100 + 12.9 + 14.4}$$

$$100 + 12.9 + 14.4$$

$$3096.9 / 127.3 = 24.3$$

*Notice as data is only given to three significant figures, the value must be given to three significant figures*

## The mass spectrum of chlorine.

Chlorine is made up of two isotopes  $^{35}_{17}\text{Cl}$  and  $^{37}_{17}\text{Cl}$  in the proportion of 3:1.

The mass spectrum of chlorine is

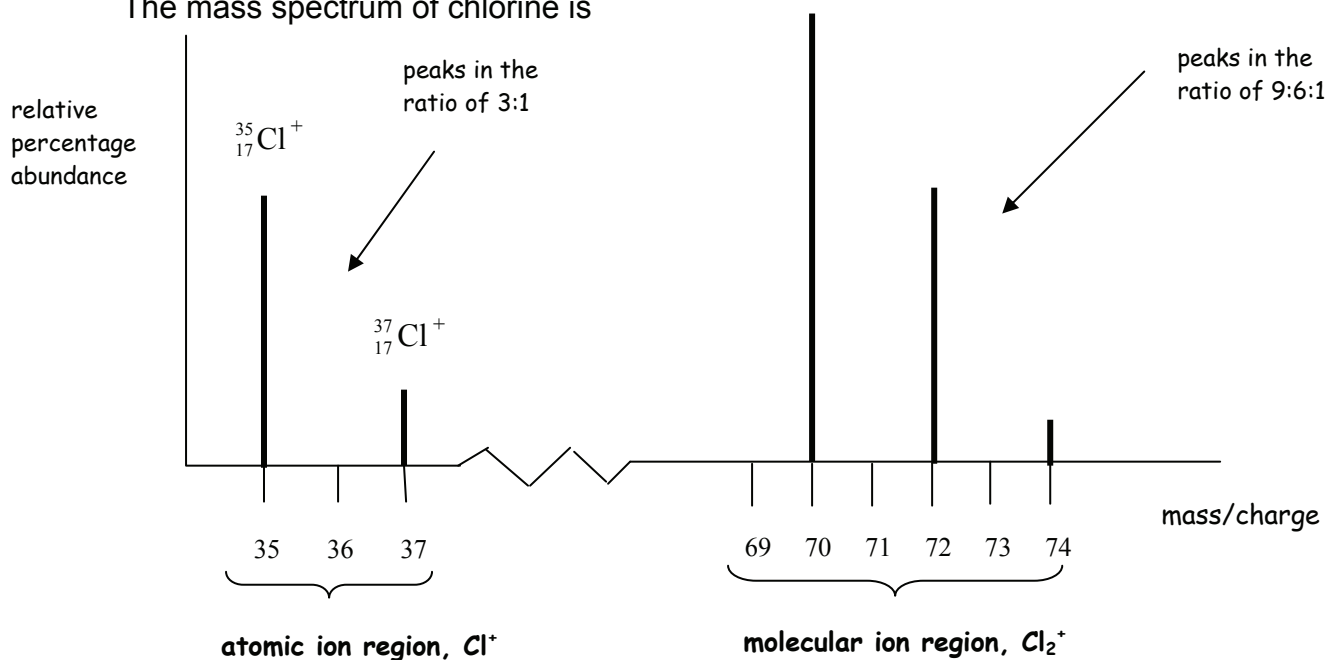

In the mass spectrometer some chlorine molecules are split into atoms which are positively charged. These ions give the peaks in the atomic ion region of mass spectrum. As the chlorine-35 isotope is three times more common than the chlorine-37 isotope, the heights of the peaks are in the ratio of 3:1.

The molecular ion region is more interesting.

### The following molecules can exist

$^{35}_{17}\text{Cl} - ^{35}_{17}\text{Cl}$  ( $m/z = 70$ ),  $^{35}_{17}\text{Cl} - ^{37}_{17}\text{Cl}$  ( $m/z = 72$ ),  $^{37}_{17}\text{Cl} - ^{35}_{17}\text{Cl}$  ( $m/z = 72$ ), and  $^{37}_{17}\text{Cl} - ^{37}_{17}\text{Cl}$  ( $m/z = 74$ ),

The probability of an atom being  $^{35}_{17}\text{Cl}$  is  $3/4$  i.e. three in every four

The probability of an atom being  $^{37}_{17}\text{Cl}$  is  $1/4$  i.e. one in every four

Probabilities are multiplied

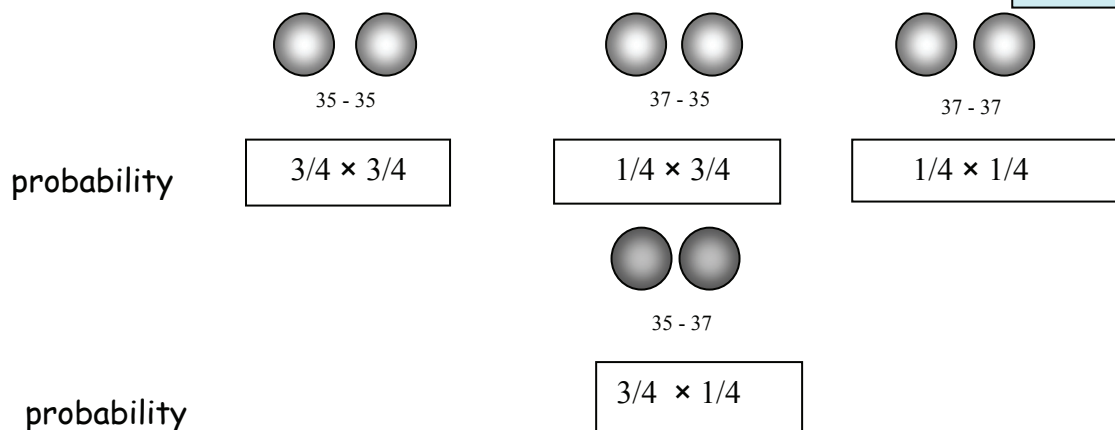

	mass/charge = 70	mass/charge = 72	mass/charge = 74
probability	$9/16$	$3/16 + 3/16$	$1/16$
ratio of peaks	9	6	1

## Topic 1.2(c)

**Learning Outcome:** *Derive empirical and molecular formulae from given data.*

**Empirical formula** is the simplest formula showing the ratios of the numbers of atoms (or ions) of each element present in the compound.

This formula can be applied to both molecular compounds and ionic compounds.

Molecular compounds contain individual molecules.

Ionic compounds are made up of a very large number of ions in crystal lattice.

**Molecular formula** shows the actual numbers of atoms of each element present in the molecule. It is used for covalent compounds which exist as molecules.

**To calculate empirical formula.**

The data provided is usually percentage composition of the compound by mass or the mass of each element contained in a given mass of the compound.

### Example 1

A compound has the following percentage composition by mass:-

Na 21.6 %; Cl 33.3 %; O 45.1%

element	% by mass	$A_r$	$\% \div A_r$	mole ratio
Na	21.6	23	0.94	1
Cl	33.3	35.5	0.94	1
O	45.1	16	2.82	3

The empirical formula is  $\text{NaClO}_3$

### Example 2

10.0 g of an oxide of iron produced 6.99 g of metallic iron on reduction. Determine the empirical formula of the oxide.

element	mass	$A_r$	$\text{mass} \div A_r$	mole ratio	whole number ratio <i>We can only have whole numbers of atoms in the formula</i>
Fe	6.99	55.8	0.125	1	2
O	$(10 - 6.99) = 3.01$	16	0.188	1.5	3

The empirical formula is  $\text{Fe}_2\text{O}_3$

For covalent molecular compounds, the molecular formula can be found from the empirical formula if the relative molecular mass or the molar mass of the compound is known.

### Example 3

Benzene, a hydrocarbon, has a relative molecular mass of 78 and contains 92.3 % carbon.

Determine its molecular formula.

element	% by mass	$A_r$	$\% \div A_r$	mole ratio
C	92.3	12	7.7	1
H	7.7	1	7.7	1

The empirical formula is CH

The molecular formula is  $\text{C}_6\text{H}_6$

## Topic 1.2(d)

**Learning Outcome:** Carry out the interconversion of grams to moles (and vice versa) for any given species

With knowledge of formula and by looking up relative atomic masses, it is possible to calculate molar masses.

Name	sodium chloride	sulphur dioxide	sodium carbonate	methane	water	carbon monoxide
Formula	NaCl	SO <sub>2</sub>	Na <sub>2</sub> CO <sub>3</sub>	CH <sub>4</sub>	H <sub>2</sub> O	CO
Molar mass/ g mol <sup>-1</sup>	58.5	64	106	16.04	18.02	28

It is now possible to convert a mass of a compound in grams to moles.

**Number of moles(n) =  $\frac{\text{mass of compound in grams(m)}}{\text{molar mass(M)}}$**

e.g. 128 g of sulphur dioxide, SO<sub>2</sub>, =  $\frac{128}{64} = 2$  moles

In the same way, it is possible to convert the number of moles of a substance to a mass in grams.

**Mass in grams = (number of moles). × (molar mass)**

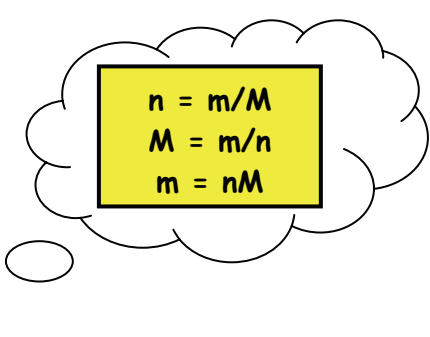
$$\begin{aligned}n &= m/M \\M &= m/n \\m &= nM\end{aligned}$$

## Topic 1.2(e)

**Learning Outcome:** *understand and use concentration data, expressed in terms of either mass or moles per unit volume.*

Much chemistry is carried out in aqueous solution and it is important to know the concentrations of the solutions that are used.

Concentrations are usually expressed as either grams per cubic decimetre ( $\text{g dm}^{-3}$ ) of solution or moles per cubic decimetre ( $\text{mol dm}^{-3}$ ) of solution

*Note that decimetre ( $\text{dm}^{-3}$ ) is a convenient volume based on the SI system of units and for all practical purposes is the same as the litre.*

**Number of Moles (n) = Concentration of solution (c) x Volume of solution (v)**

e.g. A solution of sodium hydroxide containing 4.0 g per litre of solution (concentration =  $4.0 \text{ g dm}^{-3}$ ) can be expressed as  $0.1 \text{ mol dm}^{-3}$  (grams changed into moles)

$$n = \frac{m}{M_r} \quad n = \frac{4.0}{40.0} = 0.1 \text{ mol}$$

### Example.

How many grams of hydrogen will be given off when  $50.0 \text{ cm}^3$  of hydrochloric acid of concentration  $2.00 \text{ mol dm}^{-3}$  is poured on to excess magnesium ribbon.

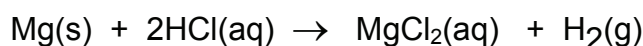

From the equation, 2 moles of HCl produce 1 mole of hydrogen ( $\text{H}_2$ ) (2.02 g)

$50.0 \text{ cm}^3$  of the acid contains  $\frac{50.0}{1000} \times 2.0$  moles of HCl = 0.100 moles

Therefore the number of moles of hydrogen is 0.05 moles = 0.101 g

## Topic 1.2 (f)

**Learning Outcome:** *calculate the mass of one reagent reacting with a given mass of another or forming a given mass of product(s), given the stoichiometry of the process;*

### Chemical calculations and the use of equations.

A chemical equation is a short-hand way of representing a chemical reaction.

The relationship of number of moles of reactants to those of products is called the stoichiometry of the reaction.

An equation giving the correct stoichiometry is called a balanced equation.

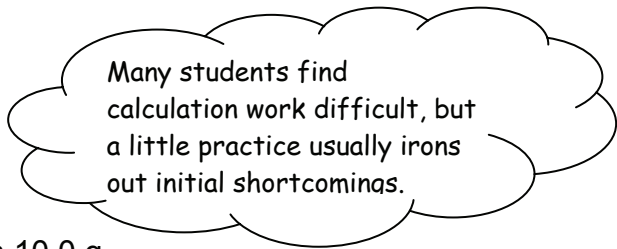

Many students find calculation work difficult, but a little practice usually irons out initial shortcomings.

### Examples of mass/mass relationships

Calculate the mass of zinc oxide formed when 10.0 g of zinc carbonate is decomposed according to

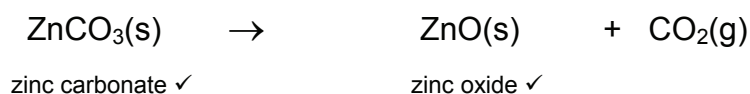

**Step 1** tick the substances concerned

**Step 2** write down the stoichiometry

*i.e.* 1 mole of  $\text{ZnCO}_3$  forms 1 mole  $\text{ZnO}$

**Step 3** Work out molar masses and produce a statement.

$$A_r(\text{Zn}) = 65.4; A_r(\text{C}) = 12.0; A_r(\text{O}) = 16.0;$$

$$124.5 \text{ g of ZnCO}_3 \text{ produces } 81.4 \text{ g of ZnO}$$

$$1.0 \text{ g of ZnCO}_3 \text{ produces } 81.4 / 124.5 \text{ g of ZnO}$$

$$10.0 \text{ g of ZnCO}_3 \text{ produces } (81.4 / 124.5) \times 10.0 \text{ g of ZnO}$$

**Answer is** 6.54 g

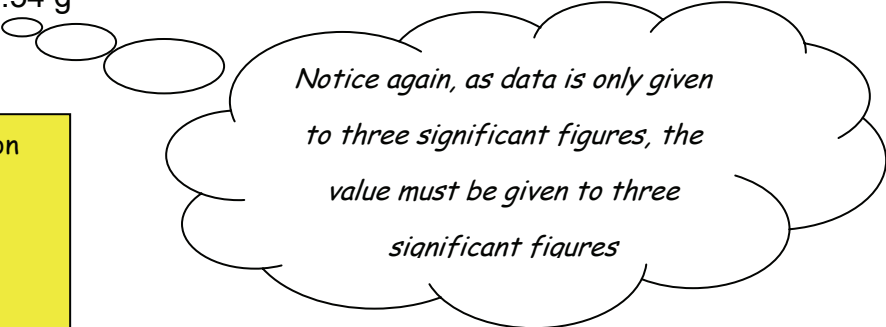

Notice again, as data is only given to three significant figures, the value must be given to three significant figures

Students who understand proportion would write down:

$$\frac{124.5}{81.4} = \frac{10.0}{x}$$

$$x = \frac{(81.4) \times 10.0}{124.5} = 6.54$$



## Topic 1.2(g)

**Learning Outcome:** use the molar volume to calculate the number of moles in a given volume of gas, at a given temperature and pressure or the volume of gas from a given number of moles.

### Molar volume

This is the volume of one mole of a gaseous element or compound under *specified conditions of temperature and pressure*.

Standard temperature and pressure is 273.15K and 101.325 kPa  
(i.e. 0 °C and 1 atmosphere pressure.)

Under these conditions, one mole of a gaseous element or compound occupies 22 400 cm<sup>3</sup> or 22.4 dm<sup>3</sup>.

To find the molar volume, in cm<sup>3</sup>, under other conditions use

$$V_m = 22,400 \times \frac{T}{273} \times \frac{P}{101.3}$$

where T is the new temperature in Kelvin and P is the new pressure in kPa.

The molar volume can be used in chemical calculations.

**Example 1.** What volume of hydrogen at s.t.p. would be produced by reacting completely 0.500 g of magnesium with excess aqueous hydrochloric acid? The equation for the reaction is

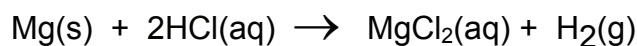

1 mol of magnesium would produce 1 mol of hydrogen

24.3 g would produce 22.4 dm<sup>3</sup> of hydrogen at s.t.p.

so 0.500 g magnesium would produce  $22.4 \times \frac{0.500}{24.3} = 0.461\text{dm}^3$ .

**Example 2.** What volume would 128 g of oxygen gas occupy at s.t.p?

Oxygen gas is made up of O<sub>2</sub> molecules.

One mole of oxygen gas is 32 g.

128 g is 4 moles and occupies  $4 \times 22.4 \text{ dm}^3 = 89.6 \text{ dm}^3$  at s.t.p.

## Topic 1.2(h)

**Learning Outcome:** *calculate the atom economy and percentage yield of a reaction using supplied data.*

### Atom Economy

When a reaction occurs, the compounds formed, other than the product needed, are waste. An indication of the efficiency of a reaction is sometimes given as its **atom economy**. It is defined as:

$$\begin{aligned}\text{atom economy} &= \frac{\text{mass of required product}}{\text{total mass of reactants}} \times 100 \% \\ &= \frac{\text{total formula mass of utilised atoms}}{\text{total formula mass of unutilised atoms}} \times 100 \%\end{aligned}$$

### Percentage yield

$$\% \text{ yield} = \frac{(\text{mass of product obtained})}{(\text{maximum theoretic mass possible})} \times 100$$

### Example:

A well-known organic reaction, called the Cannizzaro reaction, converts benzaldehyde into phenylmethanol.

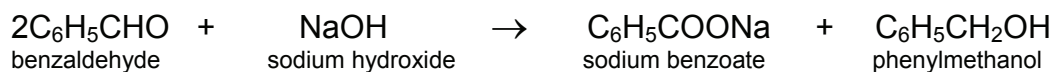

In a particular experiment, 9.6 g of purified phenylmethanol was obtained from 20.0 g of benzaldehyde. Calculate the percentage yield.

From the equation, 2 moles of benzaldehyde should produce 1 mole of phenylmethanol. Using relative atomic masses,

$2 \times (72 + 5 + 12 + 1 + 16)$  g of  $\text{C}_6\text{H}_5\text{CHO}$  should give a maximum

$(72 + 5 + 12 + 2 + 16 + 1)$  g of  $\text{C}_6\text{H}_5\text{CH}_2\text{OH}$

212 g of  $\text{C}_6\text{H}_5\text{CHO}$  should give a maximum 108 g of  $\text{C}_6\text{H}_5\text{CH}_2\text{OH}$

20.0 g of  $\text{C}_6\text{H}_5\text{CHO}$  should give a maximum  $\frac{108}{212} \times 20.0$  g of  $\text{C}_6\text{H}_5\text{CH}_2\text{OH}$

20.0 g of  $\text{C}_6\text{H}_5\text{CHO}$  should give a maximum 10.2 g of  $\text{C}_6\text{H}_5\text{CH}_2\text{OH}$

Percentage yield =  $\frac{9.6}{10.2} \times 100 = 94\%$

This is a high yield for an organic reaction. The atom economy of the reaction is

$\frac{[(\text{Formula mass of } \text{C}_6\text{H}_5\text{CH}_2\text{OH})]}{(\text{total formula masses of reactants})} \times 100$

=  $\frac{108}{(212 + 40)} \times 100 = 43\%$

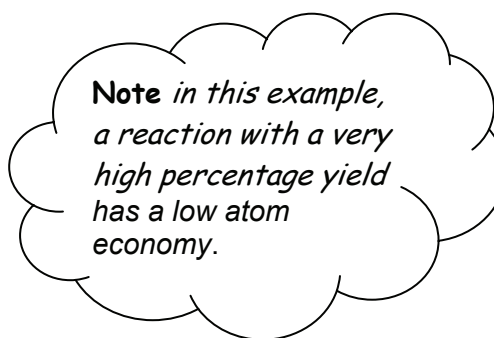

**Note** in this example, a reaction with a very high percentage yield has a low atom economy.

## Topic 2

### 2.1

### Chemical equilibria and acid-base reactions

#### Topic 2.1(a)

**Learning Outcome:** *understand the terms reversible reaction and dynamic equilibrium;*

Most chemical reactions carry on occurring until all of the reactants have turned into products or until one or other of the reactants has run out. This isn't always the case. The reaction between nitrogen and hydrogen to form ammonia is called a reversible reaction. As the ammonia builds up it starts to decompose back to nitrogen and hydrogen. Eventually, the reaction seems to stop with only about 10% of the elements converted into ammonia.

Chemical reactions have not stopped but the forward and reverse reactions are occurring at the same rate. This called a *dynamic equilibrium*.

No changes are apparent on a macro scale but reactions continue on the molecular scale.

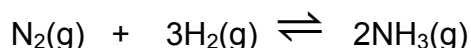

The " $\rightleftharpoons$ " sign indicates a reversible reaction.

All reactions are theoretically reversible but for most, the position of equilibrium lies either to the side of the reactants or to the side of the products.

In dealing with equilibria in later units you will use the convention of representing concentrations in  $\text{mol dm}^{-3}$  by square brackets [ ].

## Topic 2.1(b)

**Learning Outcome:** *recall and understand Le Chatelier's principle and apply it qualitatively to deduce the effects of changes in temperature and in pressure or concentration, on a system at equilibrium;*

In 1888 Henri Le Chatelier put forward his principle which dealt with the effects of constraints upon a system in equilibrium.

If the conditions of a reversible reaction are changed and disturb the equilibrium, the composition of the mixture will tend to change to restore the equilibrium and to minimize the effect of altering the conditions.

The formation of ammonia from nitrogen and hydrogen is an exothermic reaction, which means that energy is given out to the surroundings.

If a system of nitrogen, hydrogen and ammonia is in equilibrium and the temperature is raised, the equilibrium adjusts so as to oppose an increase in temperature by moving in the endothermic direction and so ammonia changes to nitrogen and hydrogen.

If the pressure is raised, the system moves so as to try to decrease the pressure by forming fewer molecules, i.e., nitrogen and hydrogen (4 moles on LHS) form ammonia (2 moles on RHS) and more ammonia is formed.

This means that in the commercial manufacture of ammonia, a high pressure and low temperature favour the yield of ammonia.

## Topic 2.1(c)

**Learning Outcome:** *understand the nature of acids as donors of  $H^+(aq)$  and bases as acceptors of  $H^+$  and apply this to their behaviour in aqueous solution;*

### Acids and bases

A very important equilibrium is the self-ionisation of water.



Sometimes written as

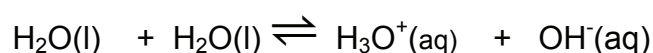

The first, simpler, equation is perfectly satisfactory.

The position of the equilibrium lies to the left and at 298 K the concentrations of

$H^+(aq)$  and  $OH^-(aq)$  are only about  $1.0 \times 10^{-7} \text{ mol dm}^{-3}$ .

(The  $H^+(aq)$  is a hydrated proton).

We know from elementary chemistry that an acid will react with a base to form a salt plus water.

Consider the simple reaction between hydrochloric acid and aqueous sodium hydroxide to form sodium chloride and water.

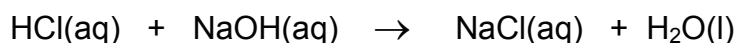

This is an example of neutralisation.

Substance	Ions present
hydrochloric acid	$H^+(aq)$ and $Cl^-(aq)$
sodium hydroxide solution	$Na^+(aq)$ and $OH^-(aq)$
sodium chloride solution	$Na^+(aq)$ and $Cl^-(aq)$
water	few ions mainly $H_2O$ molecules

The overall change is

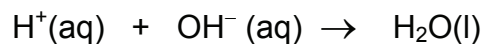

This will be the same for all similar reactions, e.g. dilute sulfuric acid and potassium hydroxide solution.

This leads to the idea that acids are compounds which, in aqueous solution, are a source of  $\text{H}^+(\text{aq})$  ions. Bases are acceptors of  $\text{H}^+(\text{aq})$  ions.

This was stated by Brønsted and Lowry who defined acids as proton donors and bases as proton acceptors. This is the Brønsted/Lowry theory of acids and bases.

An acid like hydrochloric acid is almost completely ionised in aqueous solution and is called a **strong acid**.

Ethanoic acid (acetic acid) which is found in vinegar is only partially ionised in water and is known as a **weak acid**.

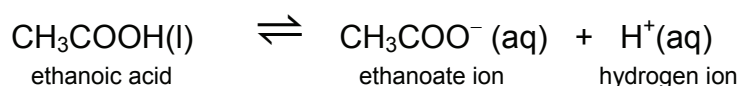

It is important to note that the terms strong and weak have nothing to do with concentration.

Concentrations are described by the words *concentrated* and *dilute* and by actual concentrations expressed as  $\text{mol dm}^{-3}$  or  $\text{g dm}^{-3}$ .

## Topic 2.1 (d)

**Learning Outcome:** appreciate the usefulness of the pH scale in describing the degree of acidity to the general public;

As explained above, the concentration of hydrogen ions in water is very small,  $10^{-7}$  mol dm<sup>-3</sup>.

The same can be said for acidic solutions. Very small numbers are inconvenient to use in everyday life. The Danish Chemist, Sørensen, devised a scale which is far more convenient, called the pH scale.



Visit <http://www.geocities.com/bioelectrochemistry/sorensen.htm>

Sørensen defined pH as  $-\log_{10}[\text{H}^+(\text{aq})]/\text{mol dm}^{-3}$

a logarithm is a function of a number and not a quantity.  
This means that in the definition of pH, the hydrogen concentration must be divided by its units, mol dm<sup>-3</sup>

Note [ ] represents concentration of H<sup>+</sup>(aq) in mol dm<sup>-3</sup>.

Thus the pH of water =  $-\log 10^{-7} = 7$  This is neutral.

If the H<sup>+</sup>(aq) ion concentration **is greater** than  $10^{-7}$  mol dm<sup>-3</sup> the solution is acidic and the pH **is less** than 7.

### The pH scale

approximate colours of universal pH indicator

pH	1	2	3	4	5	6	7	8	9	10	11	12	13	14
	strongly acidic		acidic		neutral			alkaline			strongly alkaline			

Values of pH between 1 and 14 are much more convenient for the general public who have to deal with concepts of acidity, neutrality and alkalinity.

pH values are often quoted in connection with cosmetic and beauty products. Baby shampoos always have a pH close to 7. Gardeners are often concerned with the pH of the soil.

## Topic 2.1 (e)

**Learning Outcome:** use the concept of the mole in calculations involving acid – base titration data:

### Acid-base titrations

This involves measuring the volume of one solution by a burette which will react exactly with a known volume of another solution measured with a pipette. The precise point of neutralisation is measured using an acid-base indicator (such as methyl orange or phenolphthalein). This type of analysis is called *volumetric analysis*.

Given an acid of known concentration in a burette it is possible to measure the volume of the acid which will exactly neutralise a known volume of an alkali in a conical flask and enable the concentration of the alkali to be found.

### Example 1

31.1 cm<sup>3</sup> of hydrochloric acid of concentration 0.750 mol dm<sup>-3</sup> neutralises 25.0 cm<sup>3</sup> of aqueous sodium hydroxide. Calculate the concentration of the sodium hydroxide.

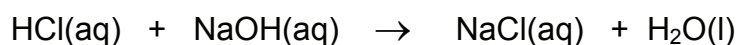

The equation shows that one mole of hydrochloric acid neutralises one mole of sodium hydroxide.

$$\text{Number of moles of hydrochloric acid} = \frac{(31.1)}{1000} \times 0.750 \text{ mol}$$

This equals the number of moles of sodium hydroxide

$$\text{i.e. } \frac{(25.0)}{1000} \times c \text{ where } c \text{ is the concentration in mol dm}^{-3}$$

$$\frac{(31.1)}{1000} \times 0.750 = \frac{(25.0)}{1000} \times c$$

$$c = \frac{(31.1 \times 0.750)}{25.0} = 0.933 \text{ mol dm}^{-3} \text{ (3 significant figures)}$$

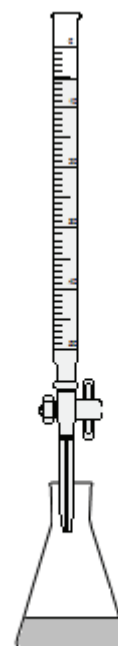

titration apparatus

### Example 2

Calculate the volume of dilute sulfuric acid of concentration  $0.040 \text{ mol dm}^{-3}$  which neutralise  $25.0 \text{ cm}^3$  of aqueous potassium hydroxide of concentration  $0.100 \text{ mol dm}^{-3}$ .

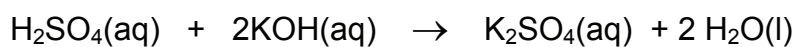

*1 mol H<sub>2</sub>SO<sub>4</sub> reacts with 2 mol KOH*

Number of moles of KOH =  $(25.0/1000) \times 0.100 = 2.5 \times 10^{-3} \text{ mol}$ .

The number of moles of H<sub>2</sub>SO<sub>4</sub> reacting is only half this amount

Therefore  $\frac{(V)}{1000} \times 0.040 = \frac{(2.5 \times 10^{-3})}{2}$

Hence  $V = 31.3 \text{ cm}^3$  (3 significant figures)

Both the above examples can be solved by remembering

$$\frac{(c_1 \times V_1)}{n_1} = \frac{(c_2 \times V_2)}{n_2}$$

where  $c_1$  and  $c_2$  are the concentrations of the two reagents in  $\text{mol dm}^{-3}$

$V_1$  and  $V_2$  are the volumes of the two reagents( must be in the same units)

$n_1$  and  $n_2$  are the respective numbers of moles of each reagent in the stoichiometric equation.

So in **example 1:**  $\frac{(31.1 \times 0.750)}{1} = \frac{(25.0 \times c)}{1}$

$c = 0.933 \text{ mol dm}^{-3}$  (3 significant figures)

and in **example 2:**  $\frac{(V \times 0.04)}{1} = \frac{(25.0 \times 0.100)}{2}$

$V = 31.3 \text{ cm}^3$

## Topic 2.1 (f)

**Learning Outcome:** *recall outline details of experimental procedures in acid-base titrations, including apparatus and methods used.*

### **Making up solutions.**

Solutions of known concentration may be made up using a **volumetric flask**. A weighed amount of solid is dissolved in a small volume of deionised water using a beaker and stirring rod. This solution is transferred to a volumetric flask using a small funnel, by pouring the solution down a stirring rod to avoid splashing. Any solution remaining in the beaker or on the funnel and rod is rinsed with deionised water into the volumetric flask. The solution is made up to the required volume by adding deionised water until the bottom of the meniscus rests on the line marked on the neck of the flask. The stopper is placed in the flask and the flask is inverted several times to ensure the solution is homogeneous.

### **Carrying out a titration.**

A clean **pipette** is rinsed with, e.g., the alkali solution (which is then allowed to run to waste). The pipette is then used to transfer a known volume of the alkali to a volumetric flask.

A clean **burette** is rinsed with, e.g., the acid solution (which is then allowed to run to waste - some of it through the jet in order to rinse the part of the burette below the tap). The burette is filled with acid using a funnel. the funnel is removed and the tap opened to fill the part of the burette below the tap. The reading is then recorded.

Indicator is added to the solution in the conical flask which is then placed on a white tile under the burette jet so that the tip of the jet protrudes a little way into the neck of the flask.

Solution is added to the flask from the burette, a little at a time, with swirling (to mix the solutions) until the addition of a small volume changes the indicator colour. The reading on the burette is again recorded and the volume of acid added is calculated. This provides a **rough titre**.

The procedure is repeated, but adding one drop at a time in the final stages, to obtain a few accurate titres.

The average of those accurate titres which are in close agreement is taken.

## Topic 2.1 (g)

**Learning Outcome:** recall that carbon dioxide is an acidic gas and its interaction with water including its effect on the carbonate / hydrogen carbonate equilibrium in sea-water.

Carbon dioxide is an acidic gas which reacts with water to set up the following equilibria,

Equilibrium 1

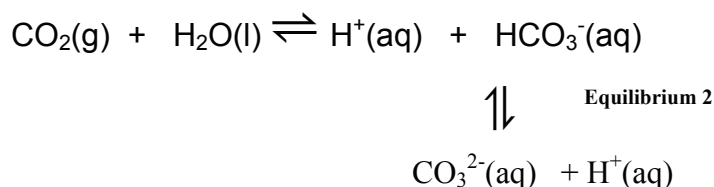

The acidity results in the erosion of limestone rock by rain water.



The aqueous calcium hydrogencarbonate decomposes in the formation of stalagmites and stalactites in limestone caverns.

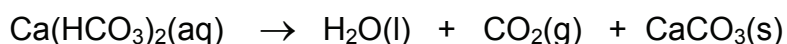

## Sea Water

The pH of sea water remains fairly constant at a value between 7.5 and 8.5. This means that sea water is slightly alkaline.

Its pH is maintained by the buffering action of dissolved carbon dioxide, hydrogencarbonate and carbonate ions and ions such as  $\text{Ca}^{2+}$  and  $\text{Mg}^{2+}$ .

[A buffer solution is one that resists a change in pH when contaminated with small amounts of acid or alkali].

There has been concern that the increase in carbon dioxide levels in the atmosphere from the combustion of fossil fuels may have a detrimental effect on the surface waters of the oceans.

Look at **Equilibrium 1** above. By le Chatelier's principle, an increase in carbon dioxide will push the equilibrium to the right and increase the concentrations of hydrogencarbonate ions and hydrogen ions. This will decrease the pH, i.e. make the water more acidic.

An increase in the concentration of hydrogencarbonate ions will affect **Equilibrium 2** moving it towards the carbonate ion side.

There are fears that this increased acidity will be detrimental to marine life, especially cold-water corals and shell-fish.

## Topic 2.2 (a)

**Learning Outcome:** *appreciate the principle of conservation of energy and construct simple energy cycles;*

The principle of conservation of energy states that energy cannot be created or destroyed only transformed from one form to another. This is the **First Law of Thermodynamics** or **The Law of Conservation of Energy**.

The change in energy is called the *change in enthalpy*,  $\Delta H$ .

Changes in enthalpy occur at constant pressure. This branch of chemistry is called energetics or thermodynamics. Thermodynamics is concerned with part of the universe called the system

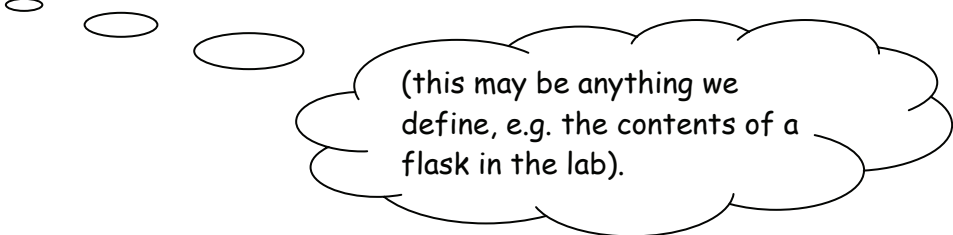

(this may be anything we define, e.g. the contents of a flask in the lab).

Thermodynamics is concerned with changes of the system.

## Topic 2.2 (b)

**Learning Outcome:** *understand that chemical reactions are accompanied by energy changes, frequently in the form of heat, and that these may be either exothermic or endothermic and depend partly on the physical state of reactants and products*

If a system changes chemically and heat is given out to the surroundings we say that an **exothermic** reaction has occurred and since the system has lost energy, the change in enthalpy,  $\Delta H$  is negative. If a system changes so that energy is taken in from the surroundings, the reaction is **endothermic** and  $\Delta H$  is positive.

## Topic 2.2 (c)

**Learning Outcome:** *define standard conditions;*

### **Standard conditions.**

Standard thermodynamic conditions are 298K and 1 atmosphere pressure. **This is not the same as s.t.p.** Standard molar enthalpy changes are referred to standard thermodynamic conditions.

$\Delta H^\ominus$  represents a **standard molar enthalpy change** for a process in which all substances are in their most stable forms at a temperature 298 K (25<sup>0</sup>C) and a pressure 101 kPa (1atm).

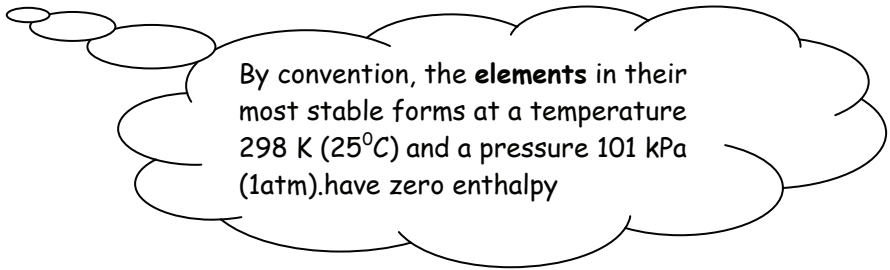

By convention, the **elements** in their most stable forms at a temperature 298 K (25<sup>0</sup>C) and a pressure 101 kPa (1atm).have zero enthalpy

## Topic 2.2 (d)

**Learning Outcome:** *understand the term enthalpy change of reaction and the specific terms enthalpy change of combustion and standard molar enthalpy change of formation,  $\Delta H_f^\ominus$  (formal definitions are not required)*

$\Delta H$  represents a **standard molar enthalpy change** for a process in which all substances are in their most stable forms at a temperature 298 K (25 °C) and a pressure 101 kPa (1 atm).

By convention, the elements in their most stable state at 298 K (25 °C) and a pressure 101 kPa (1 atm) have zero enthalpy.

**The standard molar enthalpy change of formation,  $\Delta H_f^\ominus$ ,** represents the enthalpy change when one mole of the substance (at 298 K and 1 atm) is formed from its constituent elements in their most stable form at 298 K and 1 atm.

*(At this stage of the course this formal definition is not required.)*

**The standard molar enthalpy change of combustion,  $\Delta H_c^\ominus$ ,** represents the enthalpy change when one mole of the substance (at 298 K and 1 atm) is *completely* burnt to form products (at 298 K and 1 atm).

### Some standard molar enthalpy changes of formation

	$\Delta H_f^\ominus / \text{kJ mol}^{-1}$		$\Delta H_f^\ominus / \text{kJ mol}^{-1}$		$\Delta H_f^\ominus / \text{kJ mol}^{-1}$
Al <sub>2</sub> O <sub>3</sub> solid	-1670	HCl gas	-92.3	NH <sub>3</sub> gas	-46.2
HBr gas	-36.2	HF gas	-269	CH <sub>4</sub> gas	-74.9
CaO solid	-635	CO <sub>2</sub> gas	-394	C <sub>2</sub> H <sub>4</sub> gas	52.3
CaCl <sub>2</sub> solid	-795	CO gas	-111	C <sub>2</sub> H <sub>2</sub> gas	227
H <sub>2</sub> O liquid	-286	CuO solid	-155	C <sub>3</sub> H <sub>8</sub> gas	-104
H <sub>2</sub> O gas	-242	MgO solid	-602	C <sub>6</sub> H <sub>6</sub> liquid	49.0

## Topic 2.2(e)

**Learning Outcome:** recall details of experimental procedures for determining enthalpy changes in aqueous solution, and calculate such enthalpy changes from

experimental data using 
$$\Delta H = \frac{mc\Delta T}{n}$$

Where  $m$  and  $c$  are the mass and specific heat capacity of, for example, the water used,  $\Delta T$  is the incremental change in temperature, and  $n$  is the number of moles;

The specification requires students to recall details of experimental procedures for determining enthalpy changes.

For elementary procedures a suitable calorimeter is a polystyrene cup. Such a cup has a negligible thermal capacity.

This means that the amount of heat absorbed or lost by the cup during the course of the experiment is negligible.

A typical setup is shown. Using a polystyrene cup, the thermometer can also be used as a stirrer.

The measurement of enthalpy changes of neutralisation can be measured using this apparatus, as can enthalpy changes of solution.

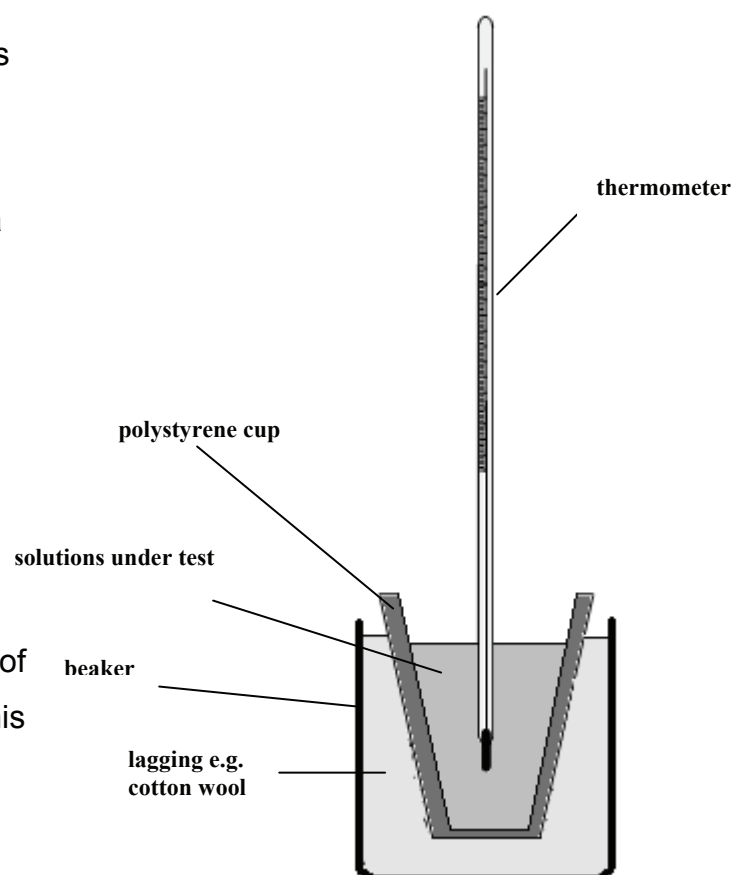

One important practical technique is to allow for heat losses to the atmosphere. To do this temperatures of solutions are taken for a short time before mixing and then again for some time after mixing. This allows for a corrected temperature rise (or loss) to be measured.

See below:

In the example shown, the temperature of the liquid(s) used is slowly increasing before mixing the reagents under test. Mixing causes an exothermic reaction and the temperature rises above that of the surroundings. It then begins to fall slowly. If the changes of temperature against time are recorded before and after mixing, the corrected temperature rise,  $\Delta T$ , can be estimated by extrapolating as shown in the diagram above.

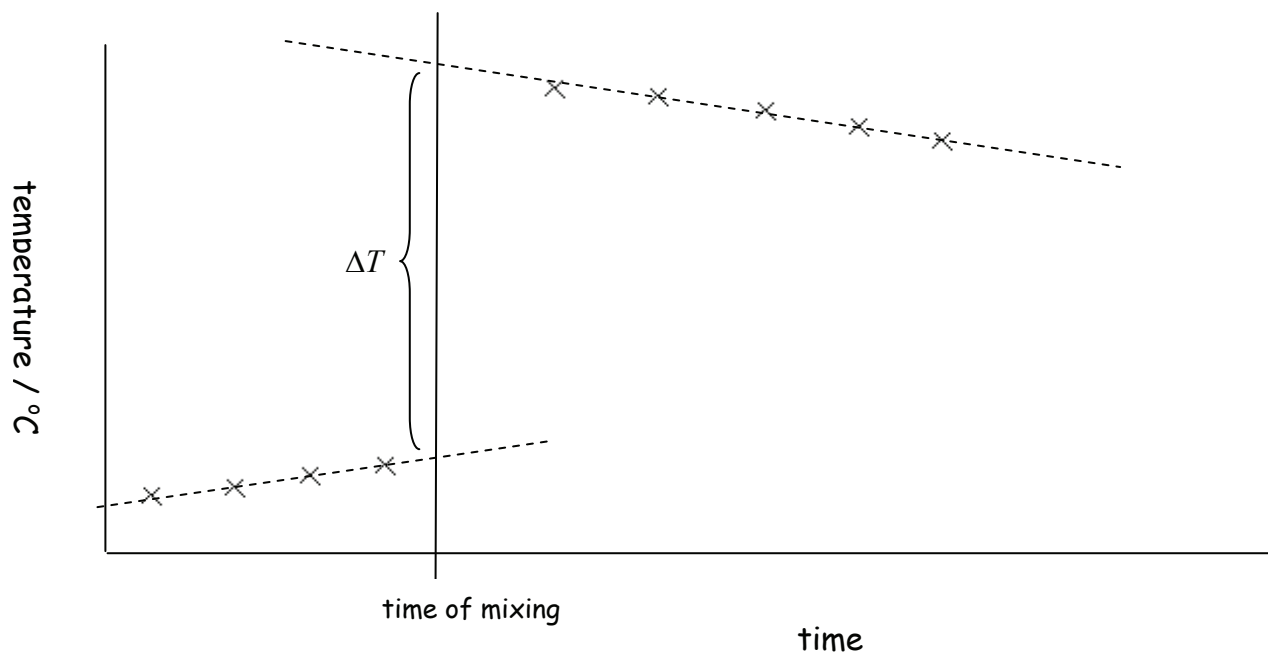

## Worked example

100 cm<sup>3</sup> of water were placed in a polystyrene cup as shown above. 10.0 g of finely ground potassium nitrate was weighed out. The temperature of the water was recorded every thirty seconds for 4½ minutes. At five minutes the potassium nitrate was quickly added to the water and the mixture vigorously stirred with the thermometer until the solid had dissolved and the temperature recording continued for some time after mixing. Calculate the enthalpy change of solution of potassium nitrate in kJ mol<sup>-1</sup>. The temperature/time graph obtained is shown below.

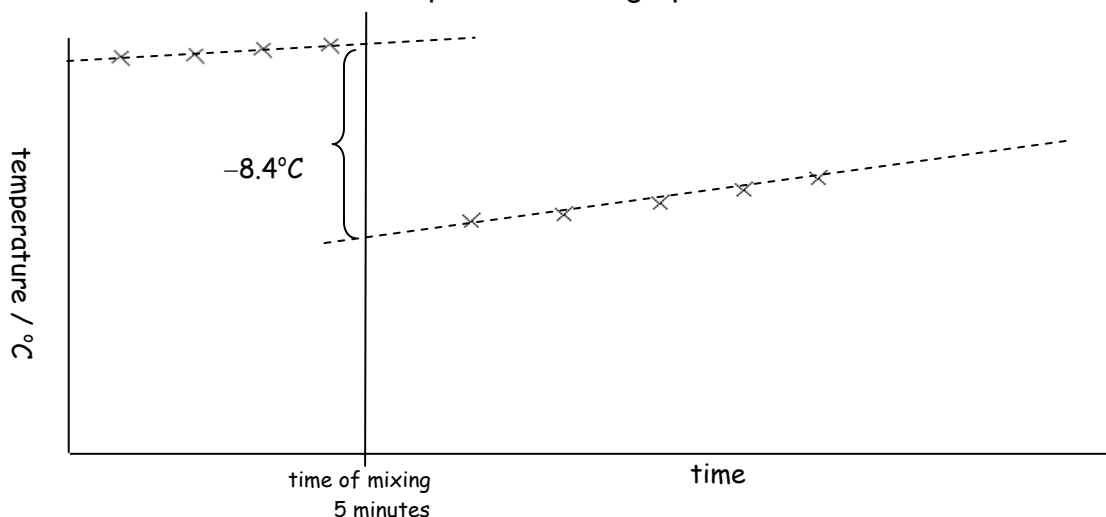

Before mixing the temperature of the water was increasing slightly. The mixing was an endothermic process and the temperature fell. After mixing the resulting solution was below room temperature and began to rise slowly.

Extrapolation of the two parts of the temperature-time graph gave a corrected temperature drop of 8.4 °C.

Candidates must be familiar with 
$$\Delta H = \frac{mc\Delta T}{n}$$

m is the mass of water = 100 g

c is the specific heat capacity of water = 4.18 J per g per °C

ΔT = -8.4 °C it is a temperature fall.

n = number of moles of potassium nitrate =  $\frac{10.0}{101} = 0.099$  mol

Substituting  $\Delta H = -(100 \times 4.18 \times -8.4)/0.099 = +35,500$  J

$\Delta H = +35$  kJ mol<sup>-1</sup> The positive sign indicates an endothermic process.

The accuracy of the experiment is such that it only justifies an accuracy of two significant figures.

It should be noted that enthalpy changes of solution vary with the concentration of the final solution.

### ALTERNATIVE UNITS

m is the mass of water = 0.100 kg

c is the specific heat capacity of water = 4180 J per kg per °C

$$\Delta H = \frac{-(0.1 \times 4180 \times -8.4)}{0.099}$$

$$= +35500 \text{ J}$$

## Topic .2.2 (f)

**Learning Outcome:** State Hess's Law and use it to calculate enthalpy changes from energy cycles

### Hess's Law

The German chemist, Hess, in 1840 stated the law of conservation of energy in a form which can be interpreted as:-

The total energy change that occurs when a system changes from one state to another is independent of the route taken to bring about the change.

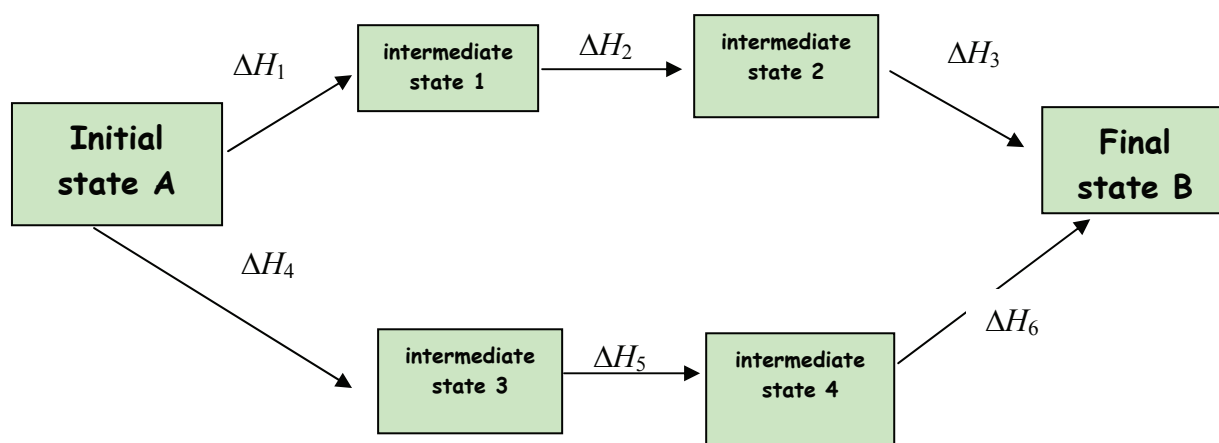

It follows that the total enthalpy change from A to B is independent of the intermediate stages in the change.

Therefore  $\Delta H_1 + \Delta H_2 + \Delta H_3 = \Delta H_4 + \Delta H_5 + \Delta H_6$

The diagram above may be called an energy cycle. Energy cycles are useful in solving energetics problems. Always try to construct a cycle and then apply Hess's law.

### Example 1

1. Calculate the enthalpy change for the reaction

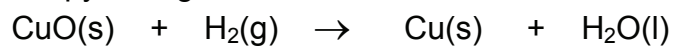

To calculate this we need to draw an energy cycle:

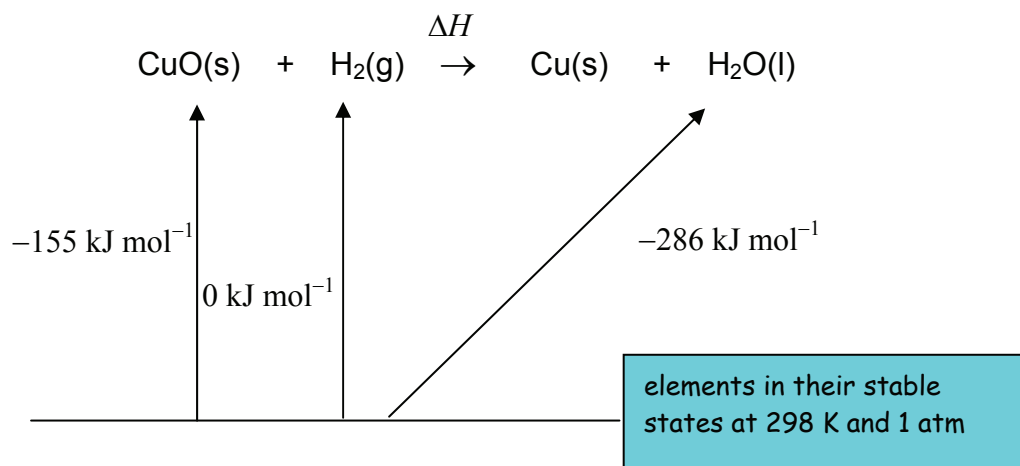

The standard molar enthalpy changes of formation are from table above.

By Hess's law  $-155 + \Delta H = -286$

Hence  $\Delta H = -131 \text{ kJ mol}^{-1}$

## Example 2

Compare the energy released per kilogram for the complete combustion of methane and for propane. Use data in table above.

### Methane

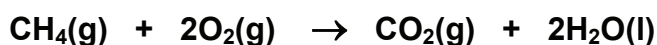

energy cycle:

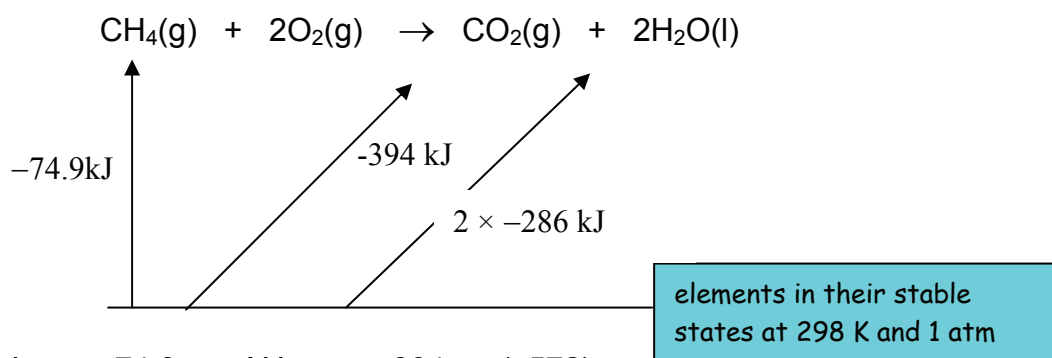

Using Hess's Law  $-74.9 + \Delta H_1 = -394 + (-572)$

Hence  $\Delta H_1 = -966 + 74.9 = -891 \text{ kJ}$

This is the enthalpy change for the combustion of one mole of methane (16 g)

The enthalpy change for the combustion of one kilogram of methane is

$$\frac{(-891 \times 1000)}{16} = -5.57 \times 10^4 \text{ kJ.}$$

### Propane

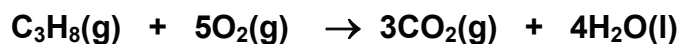

energy cycle:

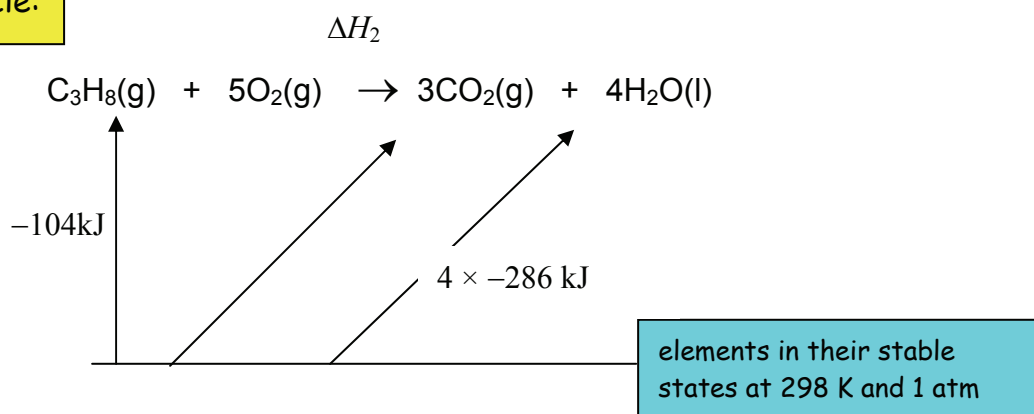

Hence  $-104 + \Delta H_2 = (3 \times -394) + (4 \times -286)$

$\Delta H_2 = -1182 - 1144 + 104 = -2220 \text{ kJ}$  (3 significant figures)

This is the enthalpy change for the combustion of 1 mole (44 g) of propane.

Enthalpy change per kg =  $\frac{(-2220 \times 1000)}{44} = -5.05 \times 10^4 \text{ kJ}$

## Topic 2.2(g)

**Learning Outcome:** *understand the concept of average bond enthalpy (energy) and use Hess's Law to carry out simple calculations involving such quantities.*

### Average Bond Enthalpy (energy)

This section of the specification refers to average bond enthalpies. Strictly speaking, we should refer to bond *dissociation* energies as the enthalpy changes involved refer to the breaking of bonds.

Remember

- Bond breaking is an endothermic process – energy absorbed
- Bond formation is an exothermic process – energy evolved

The standard molar bond enthalpy for covalent **X – Y** bond in the molecule **XY** is defined as the enthalpy change for

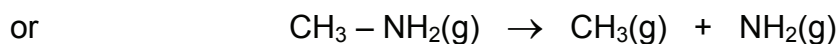
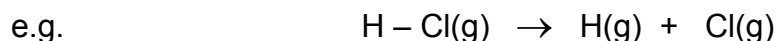
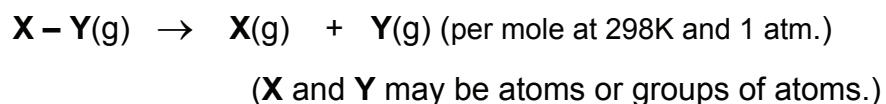

The actual value for the enthalpy change for a particular bond depends on the structure of the rest of the molecule.

If the four hydrogen atoms in methane were successively removed from the CH<sub>4</sub> molecule, the energies required each time are not the same.

We therefore take average values for bond enthalpy for a particular bond in a series of related compounds.

These values are known average or mean standard molar bond enthalpies.

Here are a selection

Bond	Average bond enthalpy at 298K and 1 atm. / kJ mol <sup>-1</sup>	Bond	Average bond enthalpy at 298K and 1 atm. / kJ mol <sup>-1</sup>
H-H	436	C≡N	890
H-O	463	C-F	484
H-N	388	C-Cl	338
H-Cl	431	C-Br	276
H-Br	366	C-I	228
H-I	299	Cl-Cl	243
H-C	412	Br-Br	193
C-C	348	I-I	151
C=C	612	F-F	158
C=O	743	O=O	498
C-N	305	N≡N	945
C=N	613	N=N	410

Other values may be obtained from a data book or from the Internet.

### Worked example.

Using the average bond enthalpies above, and the standard enthalpy of formation of liquid water as  $-286 \text{ kJ mol}^{-1}$ , calculate the enthalpy change for

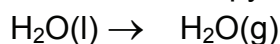

Draw an energy cycle

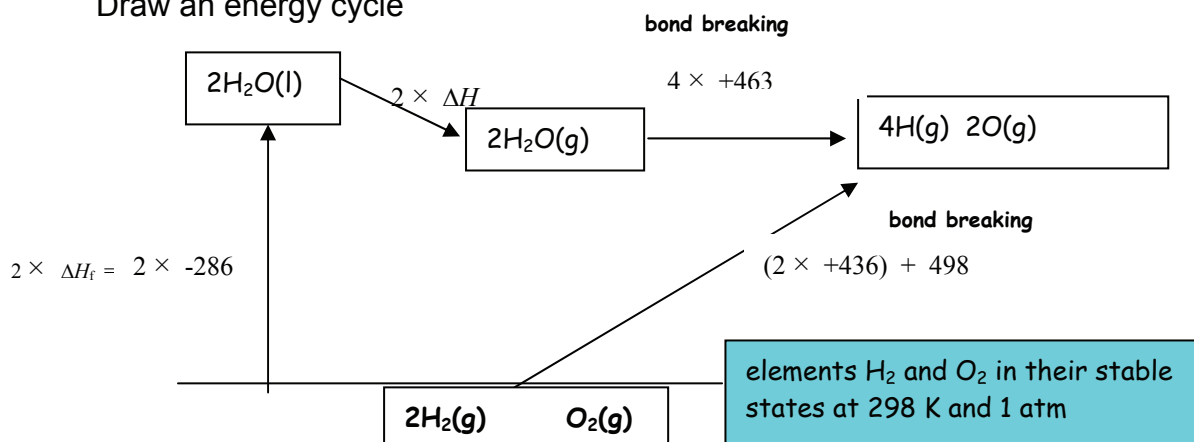

Applying Hess's law

$$(2 \times -286) + 2\Delta H + (4 \times +463) = (2 \times 436) + 498$$

$$2\Delta H - 572 + 1852 = 1370$$

$$2\Delta H + 1280 = 1370$$

$$2\Delta H = 90$$

$$\Delta H = +45 \text{ kJ mol}^{-1}$$

Note how the signs look after themselves if you remember bond breaking gives positive values and bond formation negative values.

## Example 2

Using bond enthalpies, calculate the enthalpy change of combustion of methane using the equation.

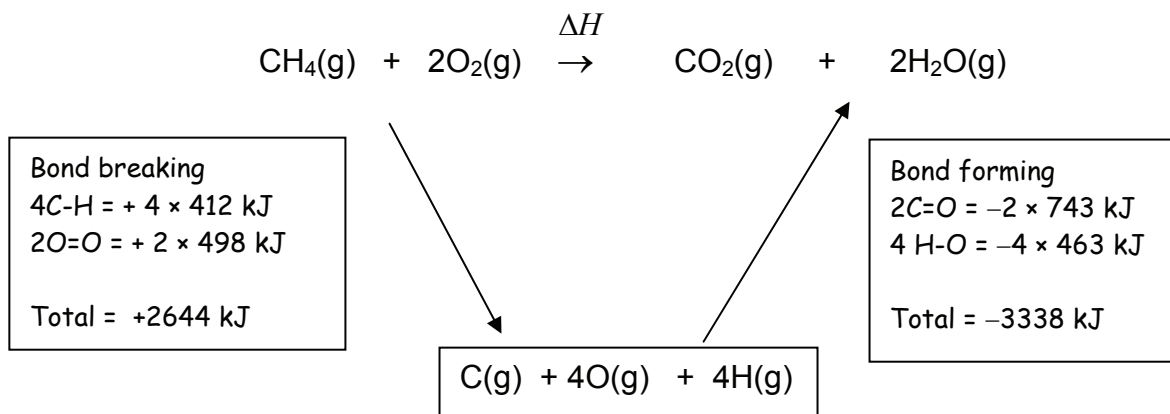

Applying Hess's law

$$+2644 + (-3338) = \Delta H$$

$$\text{Hence } \Delta H = -694 \text{ kJ mol}^{-1}$$

**Topic 2.3 (a)**

**Learning Outcome:** *name the factors affecting reaction rates, including light in some cases.*

Factors affecting the rate of a chemical reaction

- The physical state of the reactants. Finely divided solid reactants react more quickly than coarser material. The more finely divided a solid the greater the surface area available for reaction.
- The concentration of a reactant. In many cases the greater the concentration of a reactant the greater the rate of a chemical reaction. In gaseous reactions the greater the pressure of a reactant the greater the rate of reaction.
- The temperature of a reaction. The greater the temperature the greater the rate of a reaction.
- The presence of a catalyst. Catalysts increase the rate of a chemical reaction without being chemically changed by the reaction.
- The presence of light in some reactions. A mixture of hydrogen and chlorine will react explosively in the presence of right sunlight.

**Topic 2.3 (b)**

**Learning Outcome:** *outline a method of measuring the rate of a given reaction, explaining the principles involved;*

Measuring the rate of a chemical reaction

To measure the rate of a chemical reaction, we need to find a physical or chemical quantity which varies with time. Examples are

- Evolution of a gas (it is possible to measure changes in volume or pressure).
- Change in colour. The intensity of the colour of a species can be related to its concentration and measured using a colorimeter.
- Measuring pH
- Sampling. Samples are removed from the reaction mixture at various times and analysed for a particular reagent.

### Example 1

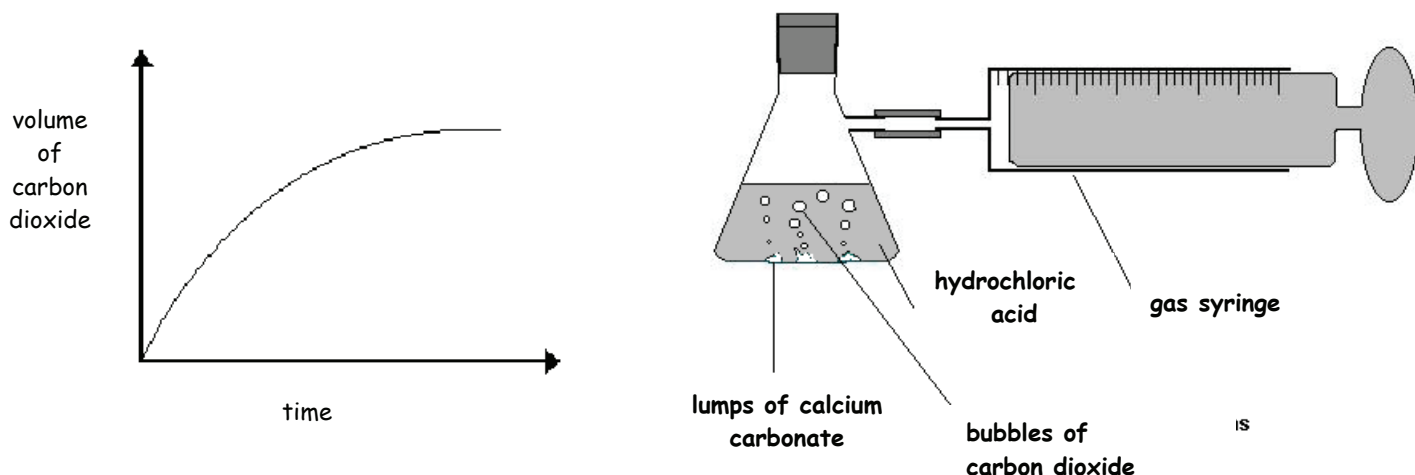
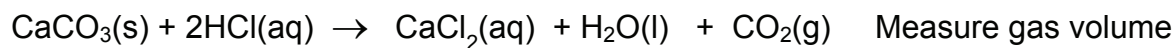

### Example 2

The same reaction could be followed by measuring loss of mass.

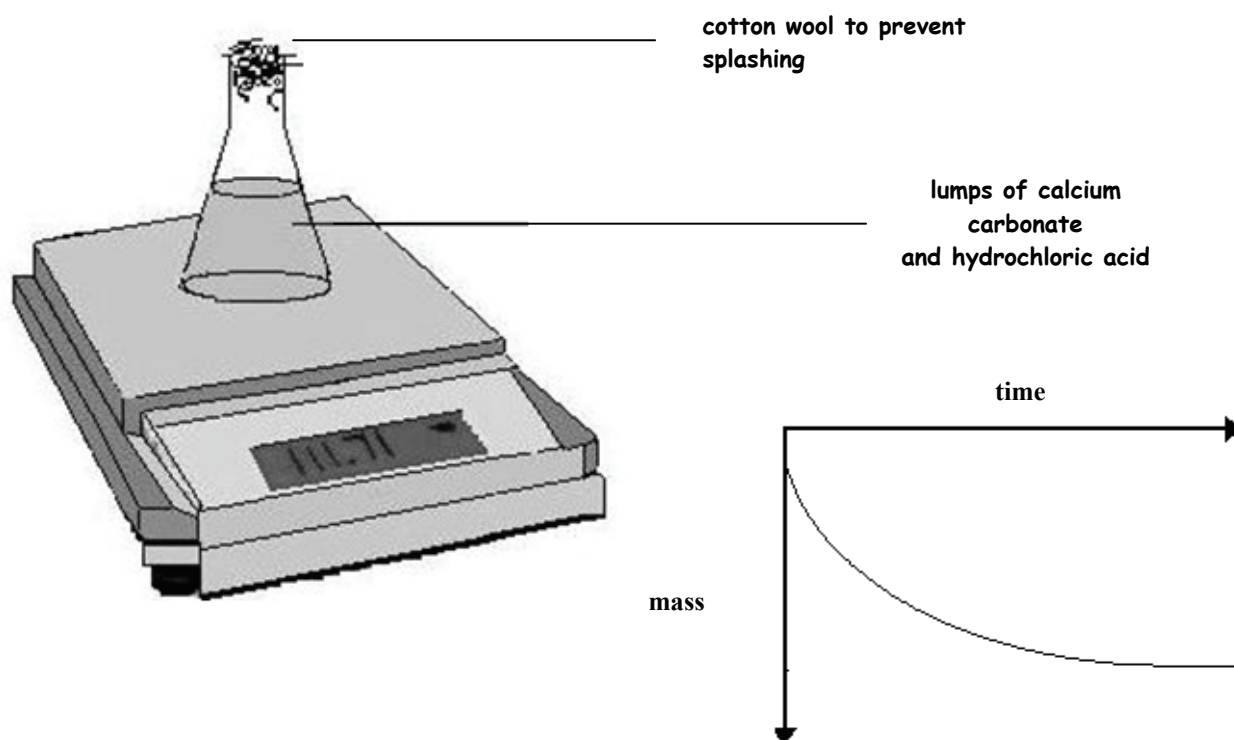

### Example 3

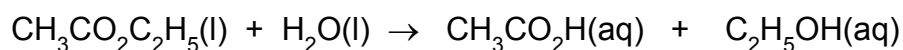

Measure the concentration of ethanoic acid by sampling.

### Example 4

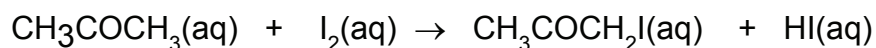

The intensity of the colour of the iodine can be monitored using a colorimeter and hence the rate of disappearance of iodine can be measured.

### Topic 2.3(c)

**Learning Outcome:** Calculate initial rates from graphs of concentration against time and understand how the results can give the relationship between rate and reactant concentrations

Studying reactions using initial rates of reaction

At the start of an experiment the concentrations of all the reagents are known.

If a graph of concentration of one of the reagents is drawn against time a plot similar to the one below may be obtained.

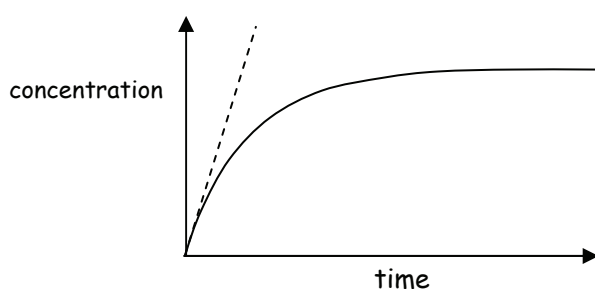

*If a tangent is drawn to the curve at time zero, then the slope of the tangent measures the initial rate of the reaction, the units are  $\text{mol dm}^{-3} \text{s}^{-1}$ .*

By performing a series of experiments in which the concentration of only one reactant is changed at a time, a relationship can be deduced between **initial** rate and **initial** concentration.

## Example

Take the reaction

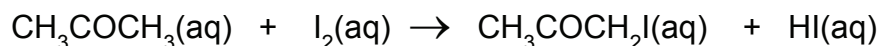

which is carried out in dilute hydrochloric acid. We can determine three initial concentrations, those of propanone (  $\text{CH}_3\text{COCH}_3(\text{aq})$ ), aqueous iodine( $\text{I}_2(\text{aq})$ ) and hydrochloric acid( $\text{HCl}(\text{aq})$ ) .

Look at the following series of experiments carried out at the same temperature..

Experiment	Initial concentrations /mol dm <sup>-3</sup>			Initial rate / 10 <sup>-4</sup> mol dm <sup>-3</sup> s <sup>-1</sup>
	I <sub>2</sub> (aq)	CH <sub>3</sub> COCH <sub>3</sub> (aq)	HCl(aq)	
<b>I</b>	0.0005	0.4	1.0	0.6
<b>II</b>	0.0010	0.4	1.0	0.6
<b>III</b>	0.0010	0.8	1.0	1.2
<b>IV</b>	0.0010	0.8	2.0	2.4

### Examining the results.

In experiments **I** and **II**, only the concentration of iodine is changed and when it is doubled there is no change in the initial rate of reaction.

This shows that the initial rate of the reaction is independent of the initial concentration of aqueous iodine.

In experiments **II** and **III** only the initial concentration of the propanone is doubled, the other two initial concentrations are kept the same. The result shows that the initial rate doubles.

Therefore initial rate is directly proportional to the initial concentration of propanone.

In the same way, experiments **III** and **IV** show initial rate is directly proportional to the initial concentration of hydrochloric acid.

This can be written mathematically as

$$\text{Rate} = k[\text{CH}_3\text{COCH}_3(\text{aq})] [\text{HCl}(\text{aq})]$$

$k$  is a proportionality constant called the rate constant.

the use of [ ] is a convention for representing concentrations in mol dm<sup>-3</sup>

Note that the initial concentration of iodine does not appear in the rate equation. The iodine still takes part in the reaction and if it is not in excess will govern the yield of the product.

The iodine does not affect how quickly the reaction takes place.

We know that chemical reactions take place by a series of simple steps called the reaction mechanism. The overall rate of the reaction depends on the slowest step which is called the *rate determining step*. If a particular reactant is not involved in the rate determining step, then it will not affect the overall rate of the reaction.

More will be dealt with in **Topic 18 Unit 5**

## Topics 2.3 (d) to (f)

### Learning Outcome:

- d) *describe simple collision theory and qualitatively explain the effects of changes in concentration (or pressure) and temperature on rate by means of this theory;*
- e) *define activation energy, describe the concept of energy profiles and recall that  $\Delta H = E_f - E_b$*
- f) *explain the rapid increase in rate with temperature in terms of changes in the energy distribution curve.*

Chemical reactions get faster as temperature increases. An approximate generalisation is that the rate of a reaction doubles with every 10 °C rise in temperature.

### Collision theory

Studies show that both in the gaseous and liquid phases reacting particles (molecules, atoms and ions) undergo a very large number of collisions or interactions every second. Rate studies show that not every one of these collisions leads to reaction. Only a small fraction of the total number of collisions leads to reaction. These effective collisions occur when the particles have sufficient energy to break bonds and form products. This minimum energy is called ***the activation energy***. Collision theory explains

1. That is the concentration (or pressure) of a reactant increases then there are more particles interacting per unit volume and there will be an increase in the number of effective collisions and the rate will increase.
2. If the temperature increases then the fraction of particles possessing the activation energy increases and so does the number of effective interactions and hence the rate.

These may be illustrated by energy distribution diagrams and energy profiles.

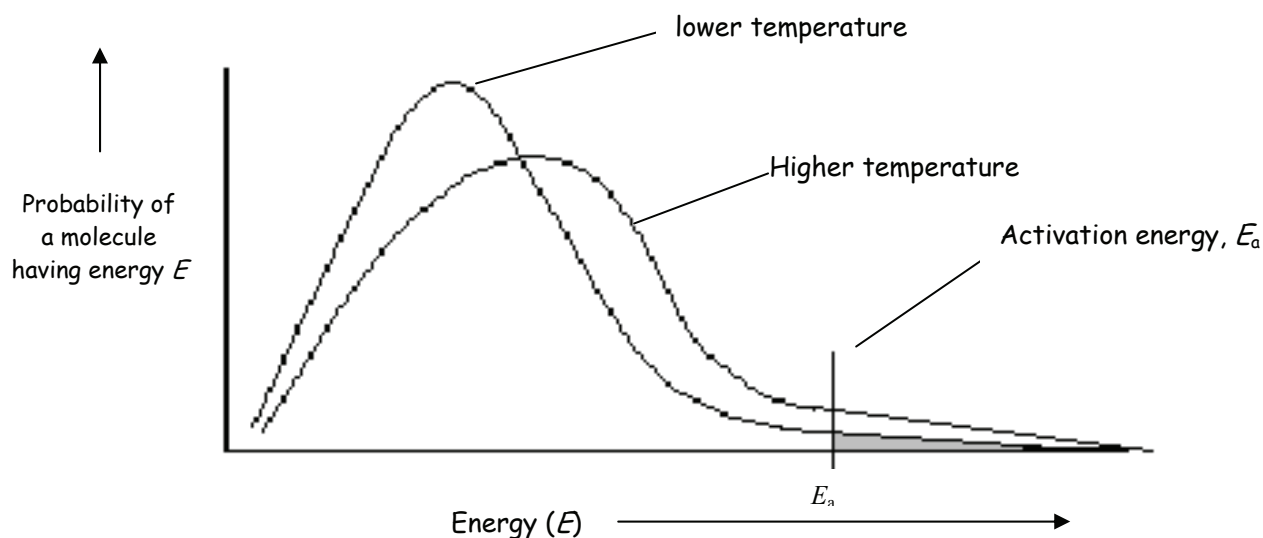

- The graph above shows two distribution curves for the same sample of gas at two different temperatures.
- The areas under the two curves are equal and are proportional to the total number of molecules in the sample.
- At the higher temperature, the peak (the most probable energy) moves to the right but is lower.
- Both curves are tangential to the energy axis
- If the activation energy for a reaction is marked as above, then the area under the curve to the right of that energy is proportional to the number of molecules possessing an energy equal to or greater than the activation energy.
- At the higher temperature more molecules possess energy equal to or greater than the activation energy.

## Topic 2(e)

### Energy Profiles

The energy profile of an exothermic reaction is shown below.

$\Delta H$  is negative,  $E_a^f$  and  $E_a^b$  are the activation energies of the forward and reverse reactions respectively.

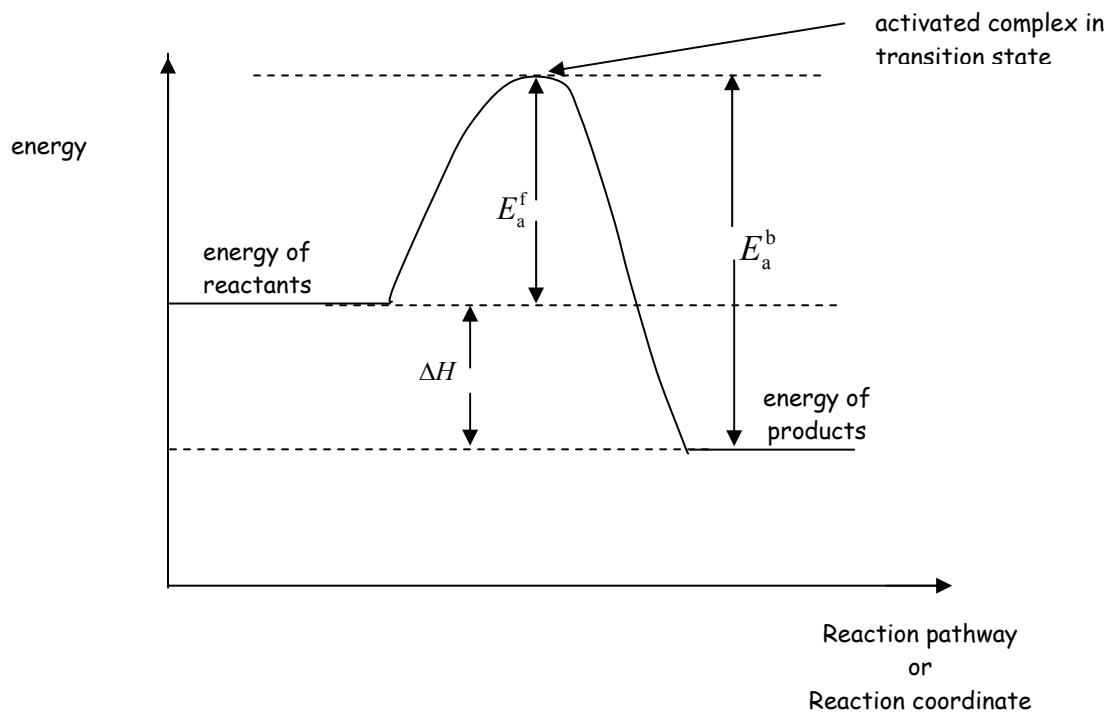

The energy profile of an endothermic reaction is below

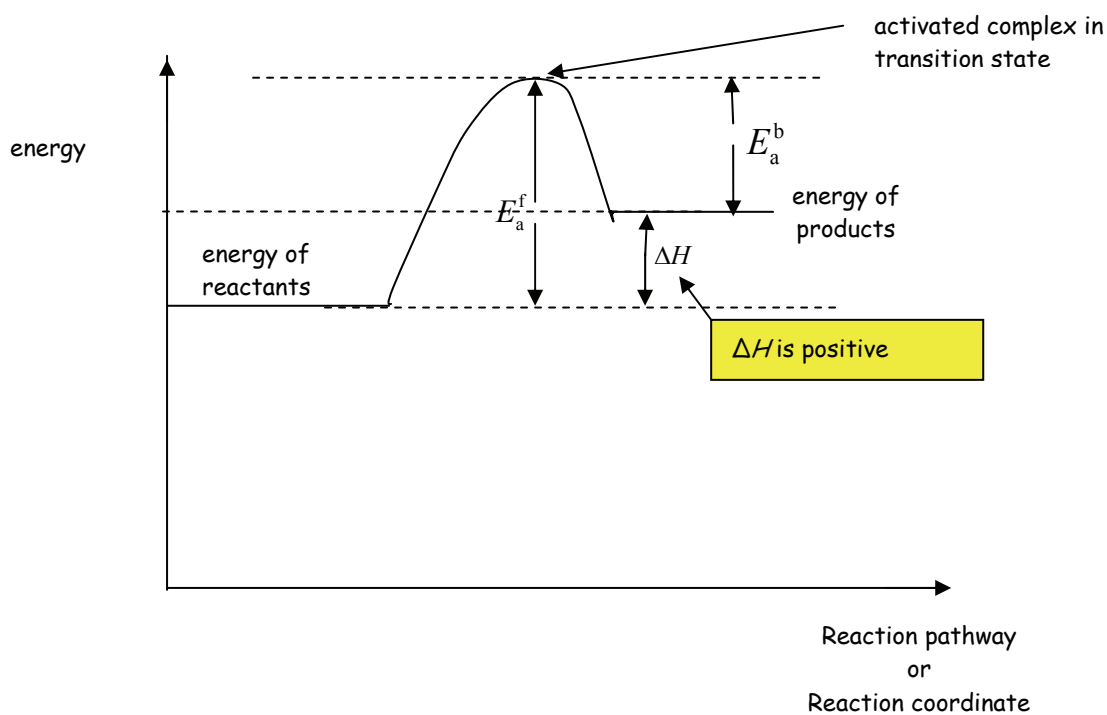

### Topic 2.3(f)

*The increase in the rate of a reaction with temperature can be explained from the energy distribution curves.*

At temperature  $T$ , the number of molecules with energy equal to or greater than the activation energy,  $E_a$ , is proportional to the area **A** under the curve. At a temperature 10 K higher, the number of molecules with energy equal to or greater than the activation energy,  $E_a$ , is proportional to the area **A + B** under the curve. Many more molecules will have sufficient energy to react and so the rate increases significantly. In the example shown the rate would increase by a factor of more than

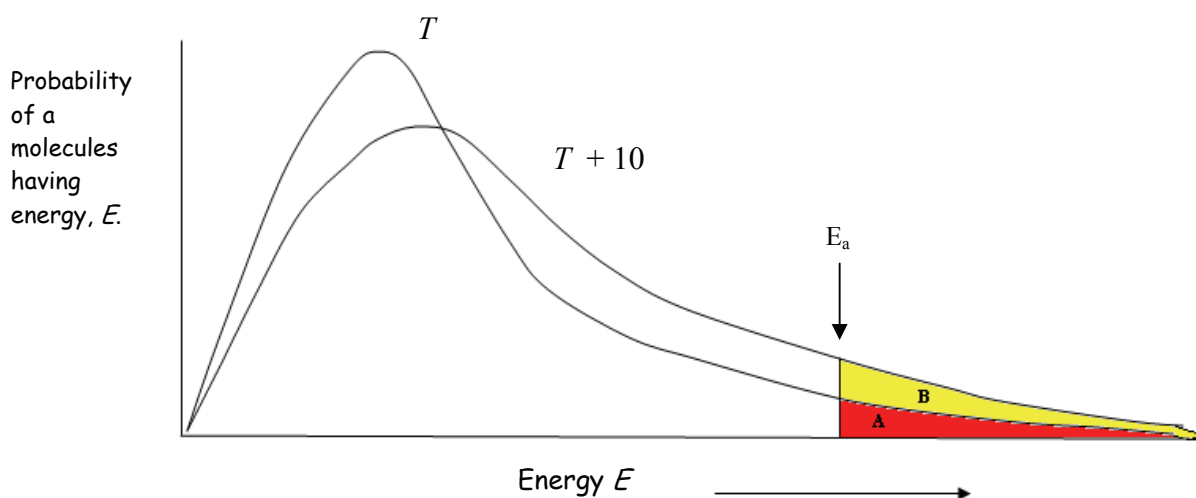

## Topic 2.3(g)

**Learning Outcome:** Recall the function of a catalyst and understand that any temperature the presence of a catalyst:

- i. Provides an alternative faster reaction pathway and thus increases the rate of both the forward and back reactions, normally by lowering the activation energy (lower energy profile);
- ii. Does not affect the position of equilibrium;
- iii. Does affect the time taken to reach equilibrium

### Catalysis.

The properties of catalysts

- Catalysts speed up reactions but are not consumed by reactions and therefore do not appear as reactants in the overall equations.
- A catalyst provides alternative reaction pathway with an activation energy lower than those of the uncatalysed reactions. This is illustrated in the reaction profile below.

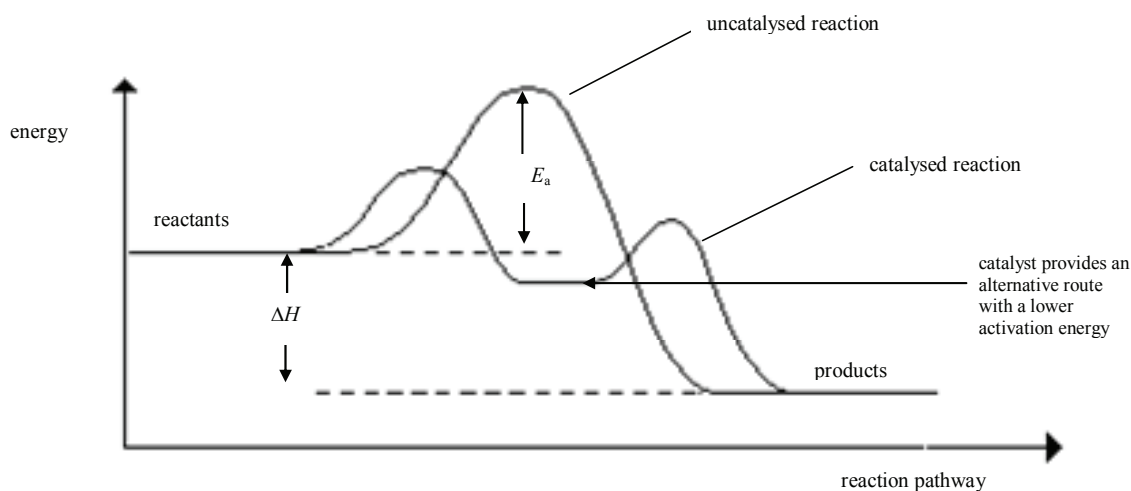

- Catalysts provide an alternative reaction pathway with an activation energy lower by the same amount than the activation energies of the forward and reverse reactions of a reversible reaction.
- Catalysts **speed up** the rate of attainment of equilibrium for a reversible reaction without altering its composition at equilibrium.

## Topic 2.3(h)

**Learning Outcome:** recall that catalysts may be homogeneous or heterogeneous and be able to give one example of each type;

### Heterogeneous catalysis

A heterogeneous catalyst is a catalyst in a *different phase* from the reactants. Often industrially heterogeneous catalysts are d-block transition metals. Iron is used in the Haber process to manufacture ammonia

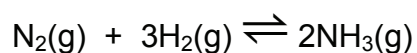

and nickel is used in the hydrogenation of a carbon-carbon double bond

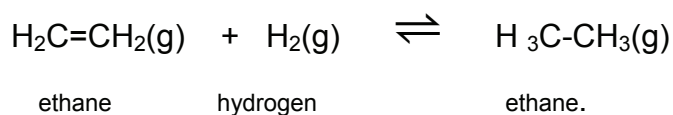

The transition metal provides a reaction site for the reaction to take place. Gases are adsorbed on to the metal surface and react and the products desorb from the surface.

## Homogeneous catalysis

- A homogeneous catalyst is a catalyst in the same phase as the reactants.
- Homogeneous catalysts take part in a reaction so an increase in their concentration may speed up the rate-determining step.

The oxidation of iodide anions by peroxodisulfate(VI) anions is slow and has a high activation energy.

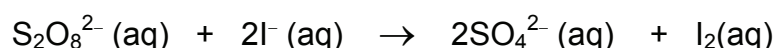

However, iron(II) or iron(III) cations catalyse the reaction by taking part and providing an alternative pathway with a lower overall activation energy. Aqueous iron(II) ions,  $\text{Fe}^{2+}(\text{aq})$ , or aqueous iron(III) ions,  $\text{Fe}^{3+}(\text{aq})$ , catalyse the reaction. Aqueous iron(II) ions reduce peroxodisulfate(VI) ions

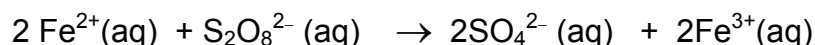

and  $\text{Fe}^{3+}(\text{aq})$  ions oxidize iodide ions

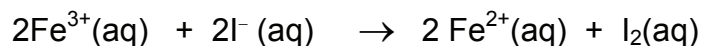

These reactions have much lower activation energies than the direct reaction

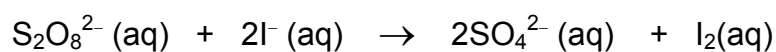

In the formation of an ester from a carboxylic acid and an alcohol, concentrated sulfuric acid behaves as a homogeneous catalysis being involved in protonation of the alcohol.

## Topic 2.3(i)

**Learning Outcome:** *appreciate the importance of finding new and better catalysts, including the use of enzymes, in achieving some of the goals of green chemistry, e.g., allowing the possibility of lower temperatures (less energy consumption), lower pressures, etc.;*

At the time of writing research is taking place examining the role of bacteria in uranium mining waste to isolate nanoparticles of palladium which can be used in catalytic converters.

Nissan Motor says it has developed a new catalyst for petrol-powered cars that needs only half the precious metals of current catalysts. The new technology uses "a significantly less amount of precious metal" but performs just as well as existing catalysts. Petrol-engine catalysts use a mix of platinum, rhodium and palladium react with the exhaust gases to convert nitrogen oxide, carbon monoxide and hydrocarbons into non-toxic compounds such as nitrogen, water and carbon dioxide (CO<sub>2</sub>). The new technology employs nano-technology which prevents the noble metals from clustering.

All these new developments are designed

- to make the particular industry more profitable
- to reduce energy and materials costs
- to make the industry more green

Enzymes are biological catalysts which sometimes have industrial applications, e.g. the enzymes from yeast in fermentation. Enzymes work under extremely mild conditions. Chemical catalysts often work only under severe conditions such as high temperatures and pressures.

Efforts to produce greener chemical processes may involve catalysis by enzymes using the milder conditions which save on energy and expense.

## Topic 2.3(j)

**Learning Outcome:** *appreciate the distinction between what may be deduced from **equilibrium** data and what may be deduce from **kinetic** data.*

Equilibrium and thermodynamic data are related. The value of an equilibrium constant shows how far a chemical reaction will proceed before equilibrium is established. Thermodynamic data provides information on the feasibility of reaction. Many feasible reactions with adequate equilibrium constants do not take place under normal conditions. The reason is that equilibrium data give no information about the kinetics of the reaction. If the activation energy is very high, the reaction may be so slow as to provide no detectable change.

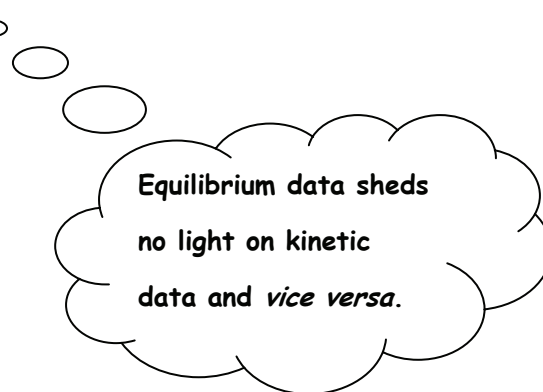

## TOPIC 3

## Application of the principles studied in unit 1 to problems encountered in the production of chemicals and of energy

### Topic 3(a)

#### Learning Outcome:

*When supplied with relevant data, candidates should be able to apply principles from Topics 1 and 2 to a wide range of processes;*

Students will be expected to apply the principles in this unit to familiar and unfamiliar processes.

For chemical engineers running industrial processes there are two extremely important tasks that must be undertaken

- A Mass Balance

This involves accounting for the total mass of reactants and the total mass of products including waste products and emissions. The principles involved in chemical calculations and equations will be most important. Remember for unfamiliar processes all relevant data will be given.

- An Energy Balance

This involves accounting for the total input of energy and the total output of energy including waste energy which is given out to the environment. Students should appreciate the role of water as a cooling medium to remove heat evolved in the process.

## Topic 3(b)

### Learning Outcome:

*When supplied with relevant data, candidates should be able to evaluate the social, economic and environmental impact of chemical synthesis and the production of energy;*

In addition to the concerns above, the development of a chemical process must consider

- 1. Social implications.** This can include availability of labour, impact on local amenities, use of land (brown field v green field sites)
- 2. Economic factors** Siting the plant - Depending upon the scale of operation, choices have to be made and these will be commercial decisions. Local Authority planning permission must be granted for any new development. There may be financial incentives to set up in some areas. Transport considerations are important. Many new plants are set up in or around existing concentrations of industry since there are relatively few companies that have sufficient wealth to start a new venture. Where existing concentrations of industry exist, there are likely to be existing transport and communication links, a working population to employ and availability of services such as energy and water.

The following are some of the points with which a company would be concerned:

- Market research as to the viability of selling the product.
- Research and development on the process. This may involve the building of a pilot plant
- Thorough costing of the process and predictions of selling price and the time taken for the company to make a profit on the operation.
- Mass and energy balances for the process.
- Safety and environmental considerations.

Costs of the process:

- Research and development
- Capital cost of the plant
- Depreciation. This takes into account the life of the plant.
- Labour costs. In modern chemical plants the number of operators is small. The cost of labour is therefore fairly constant and often varies little with the throughput of the plant.
- Raw materials (including the provision of coolant water)
- Energy costs
- Waste disposal costs and safety measures

### **3. Environmental factors:**

- Environmental impact including nature of discharges and energy consumption.
- Environmental considerations are very important especially when "Polluter Pays"

### Topic 3(c)

**Learning Outcome:** *appreciate the role of Green Chemistry in helping to achieve sustainability;*

### Green Chemistry

This involves the necessary manufacture of chemicals with minimum effect on the environment. Chemical manufacturers are responsible and highly regulated by legislation. It is also in the interest of the companies and their shareholders to consider each of the following.

1. To keep waste to a minimum. By-products of processes can often be utilised to produce a saleable product rather than being waste. An example is the absorption of waste chlorine in aqueous sodium hydroxide to form bleach (aqueous sodium chlorate(I)).
2. Where possible companies use renewable resources. The manufacture of aluminium requires large amounts of electricity Aluminium producers site their plants near hydroelectric schemes.
3. Energy costs money. Wherever possible, energy costs are kept to a minimum. Insulation and plant design contribute. The hot gases from the top of a blast furnace are used to pre-heat the air blown in at the bottom.
4. Catalysts make reactions proceed more quickly at the same temperature. By using catalysts reactions will proceed more quickly at low temperature, hence saving energy and money. Enzymes are effective at lower temperatures than many inorganic catalysts.
5. Non-toxic reactants are used wherever possible. Where a product is toxic, research is carried out to find a less toxic one.
6. Waste products are treated to give non-toxic materials which do not harm the environment. In recent time biological agents have been used to treat hazardous waste. Some hazardous organic materials can be treated with bacteria which degrade the organic molecules to methane which can be used as a fuel.

Visit <http://www.epa.gov/gcc/pubs/principles.html>



Green chemistry helps to sustain a viable chemical economy. Recycling reduces the depletion of non-renewable resources. Recent European legislation has been applied to the disposal of electronic equipment which contains a number of expensive materials which can be recovered.

<http://www.rsc.org/Publishing/Journals/gc/Article.asp?Type=CurrentIssue>



<http://www.rsc.org/Publishing/Journals/gc/index.asp>



A report from the University of Wisconsin in 2007 states that research is in progress to produce liquid alkanes from glycerol and water. Glycerol is a by-product of biodiesel.

The scheme can be shown diagrammatically below.

